Abebe R, Vakil G, LoCalzo G, Cox T, Lambert S, Johnson M, Gerada C, Mecrow
B. [Integrated Motor Drives: State of the Art and Future Trends](#). *IET Electric
Power Applications* 2016

Copyright:

This paper is a preprint of a paper accepted by IET Electric Power Applications and is subject to Institution of Engineering and Technology Copyright. When the final version is published, the copy of record will be available at IET Digital Library

DOI link to article:

<http://dx.doi.org/10.1049/iet-epa.2015.0506>

Date deposited:

05/09/2016



This work is licensed under a [Creative Commons Attribution-NonCommercial 3.0 Unported License](#)

This paper is a postprint of a paper submitted to and accepted for publication in IET Electric Power Applications and is subject to Institution of Engineering and Technology Copyright. The copy of record is available at IET Digital Library.

Integrated Motor Drives: State of the Art and Future Trends

Robert Abebe¹, Gaurang Vakil¹, Giovanni Lo Calzo¹, Thomas Cox¹, Simon Lambert², Mark Johnson¹, Chris Gerada¹, Barrie Mecrow²

¹ Department of Electrical and Electronic Engineering, University of Nottingham, University Park, Nottingham, UK

² School of Electrical and Electronic Engineering, Newcastle University, Newcastle upon Tyne, UK

Abstract: With increased need for high power density, high efficiency and high temperature capabilities in Aerospace and Automotive applications, Integrated Motor Drives (IMD) offers a potential solution. However, close physical integration of the converter and the machine may also lead to an increase in components temperature. This requires careful mechanical, structural and thermal analysis; and design of the IMD system.

This paper reviews existing IMD technologies and their thermal effects on the IMD system. The effects of the power electronics (PE) position on the IMD system and its respective thermal management concepts are also investigated. The challenges faced in designing and manufacturing of an IMD along with the mechanical and structural impacts of close physical integration is also discussed and potential solutions are provided. Potential converter topologies for an IMD like the Matrix converter, 2-level Bridge, 3-level NPC and Multiphase full bridge converters are also reviewed. Wide band gap devices like SiC and GaN and their packaging in power modules for IMDs are also discussed. Power modules components and packaging technologies are also presented.

1. Introduction

Over the last two decades there has been a shift from traditional physically separated motor and drive systems to more compact, power dense, motor-drive combinations [1]. This new power-dense motor-drive structure combines both the motor and its associated control and drive circuitry within a single enclosure. The earliest records of commercially available motor-drive systems were manufactured by Grundfos in 1991 and Franz Morat KG in 1993 [2].

These compact systems have been called a variety of names from ‘smart motors’ to ‘integrated motors’, the latter forming the foundation for the new moniker currently identified with these systems [3]. The term ‘Integrated Motor Drive (IMD)’ is the latest associated with this class of products and is as a result of the success of a TB Woods Inc. manufactured motor-drive registered under the same name [3].

IMDs are increasingly being developed and produced by machine manufacturers due to the significant potential benefits they offer. The most significant of these benefits include direct

replacement of inefficient direct on line motors, increased power density, lower losses and lower costs compared to separate motor and drive solutions. Technological advancements over the last decade have led to the development of robust electronic components able to withstand the harsh environments required by some forms of integration [4]. By eliminating separate enclosures and long cable runs, the integrated approach promises to lower system costs by 20 to 40% [5].

Elimination of transmission cables has economic advantages, including increased reliability due to the removal of the output filter commonly required for long cables. Removal of long cable runs and integration into a single package will also significantly reduce potential electromagnetic interference (EMI). This allows for EMI testing and prevention measures to be applied to the overall package at the point of manufacture. The space requirement for a separate converter will be eliminated and overall system size may be reduced compared to a traditional separated solution [6], [7]. Commissioning and testing time can also be potentially reduced by performance testing of the converter and machine as a single unit [6], [8] and [9]. This will also eliminate the need for inverter control rooms and ventilation equipment as the integrated motor and drive can also utilise a singular cooling system, further reducing size and cost of the IMD compared to a separated solution [10]. Integrating the motor and drive will also allow for increased automation of the manufacturing process [11].

Various power electronic integration approaches have been proposed in the literature ranging from a simple mounting of the converter on the machine housing to high levels of modular integration.

To take advantage of the benefits of an IMD it is important to define what it is. For the purpose of this work - an IMD is the result of the functional and structural integration of the power electronics converter with the machine as a single unit taking into consideration the electrical and structural and thermal impacts both components have on each other and the system as a whole.

All IMD units fulfil the functional electrical integration of the power electronics with the machine, as this is a defining feature of an IMD. However, the structural integration is a design problem which requires careful mechanical and thermal analysis of the converter and machine as a single unit. This is a challenge for designing and manufacturing an IMD.

Despite the attractive benefits IMDs present, reservations still exist about their widespread use. A simple addition of power electronics to the machine adds volume to the combination if the structures are not properly physically integrated. Having the power electronics in close proximity to the machine (anywhere on or inside the housing) poses a thermal management

problem for the entire system. Until recently, above 7.5 kW output, the effects of heating from both machine and drive build up significantly and present a practical limit for the manufacture of higher power drives [3], [6]. The physical size of the converter also limits the practical power rating of commercial IMD units up to the 7.5kW limit. Commercialisation of higher power and larger size IMDs will require more complex designs and impact product costs [1], [4]. Above this 7.5 kW threshold, traditional separated motor-drive systems might offer a better alternative hence the dearth in high power commercially available IMDs.

Unlike the machine, the Power Electronic (PE) converter and associate control electronics are rarely considered either mechanically or thermally robust. Without proper thermal management, placing the PE close to the machine (the prominent heat source) might cause irreparable damage to the drive. There are also problems of vibrations which could damage the internal electrical connections of the converter and decrease the expected PE lifetime. Limitations due to lack of available space in the motor and the need to adapt the power converter to the electromagnetic field stresses inside the motor housing also pose major issues. This paper reviews existing IMD configurations based on the mounting position of the converter, the benefits they provide and the challenges they face. Converter topologies, converter packaging and existing passive technologies for IMDs are also presented

2. Principal Types of Integrated Motor Drive (IMD)

Despite significant awareness of IMDs in industry, extensive research and literature on the topic, very little work exists on complete power electronics and machine integration. The majority of literature and research exists as reviews of present IMD technologies and market perspective [12-16], finite element analysis (computer simulations) [17], [18] and functional integration [19].

Due to spatial restrictions for physical integration of power electronics on or inside the motor housing, the complete structural power electronics integration research and documentation can be divided into three major categories namely – Surface Mount Integration, End Plate Mount Integration and Stator Iron Mount Integration.

2.1. Surface Mount Integration

This involves the physical mounting of the power converter on the motor housing. Different variations of this concept have been proposed – from a simple mount of the power electronics on the case of the motor to modularising the power converter and mounting the smaller converter units on the motor housing [19-24]. In Fig. 1(a), a simple addition of power

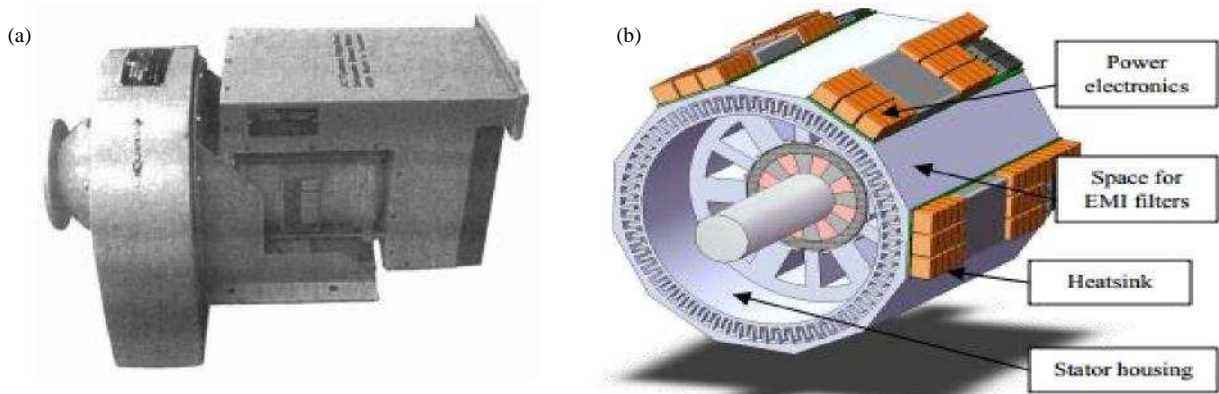

Fig. 1 Surface mount integration. (a). Simple addition of power electronics case on electric motor [21]. (b) Modularised converter units mounted on motor housing [22].

electronics on the motor is shown while Fig. 1(b) shows a modularized converter mounted on the motor housing. A shared or separate cooling system could be adopted depending on application and power density requirements.

This mode of integration is particularly attractive because of its simplicity, low cost of manufacturing and relative ease of implementation [16], [23]. The housing acts as a thermal barrier providing thermal isolation between the converter and the machine (particularly the stator windings – a major heat source). The thermal management of the casing must guarantee full absorption of all of the power electronic heating loss and all of the radially conducted heating loss from the machine. By redesigning the housing to accommodate an active cooling system [20], it can also act as a heat sink for the PE and converter (common thermal node) by offering a larger surface area for heat transfer and dissipation. The housing also provides mechanical stability and a mounting surface for the converter [21]. Extra thermal management and cooling mechanisms can be adopted for high power density motors where stator winding temperatures reach and sometimes exceed 200°C. Forced air cooling using fins embedded in the stator housing is employed in [22] and [20] utilises a liquid cooling system by running water pipes through the stator housing.

Numerous commercially available surface mounted IMD configurations exist, with the majority focused on pumps, fans and compressor applications. Low power ratings are available, with Schneider offering the Lexium 32i range with power ratings from 0.4-2.2 kW [25]. Danfoss offer mid power range IMDs up to 7.5kW [26] and VEM Motors [27] offers a line of IMDs (compact Line) with power ratings up to 30kW. High power IMDs are also commercially available with the Siemens SIVETEC series for electric vehicles (EV) offering surface mount

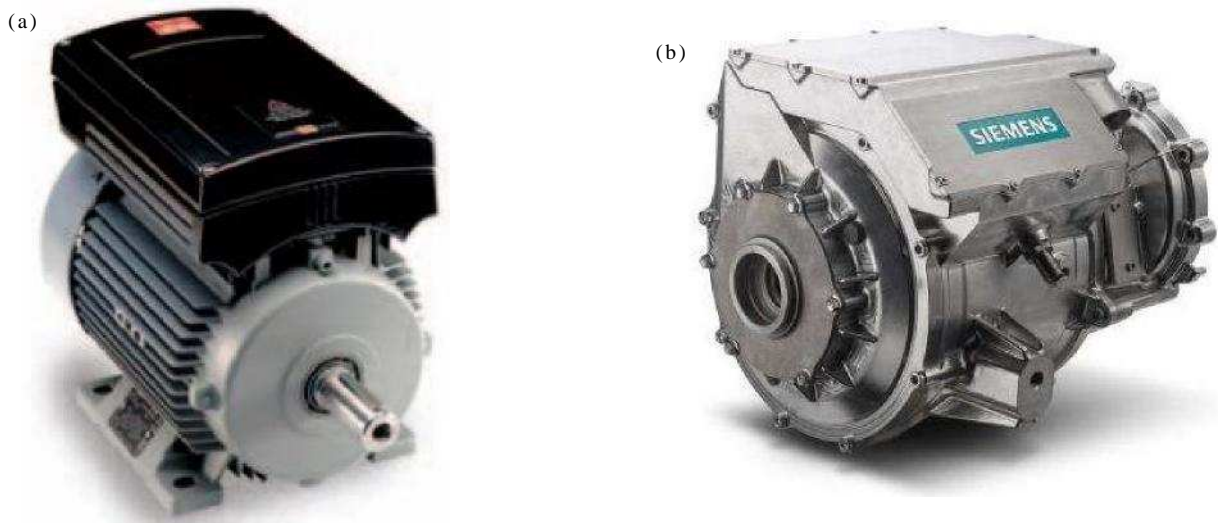

Fig. 1. (a) Danfoss VLT DriveMotor LCM 300 [26]. (b) Siemens SIVITEC MSA 3300 [28]

IMD systems from 30 kW-200 kW range with power densities up to 2.6 kg/W [28]. This large range of power ratings highlights the numerous possibilities available when adopting this configuration, with limitations largely being application dependent.

Recent commercially available surface mount IMDs suggest a shift from a more centralised surface mounted converter to a modular structure. Lenze offer modular low to midrange IMDs with power ratings ranging from 0.4 – 7.5kW [29]. Commercial high power modular IMDs with ratings up to 16.5 MW are currently manufactured by Siemens under the Integrated Drive Systems (IDS) range [30].

2.2. End Plate Mount Integration

This is a variation of the surface (radial) mount configuration with converter mounting position dependent on available space in the axial direction. Like the surface mount, the end plate mount configuration provides a stable mechanical platform for the converter. It also provides thermal isolation of the power electronics from the machine. In the example published in literature [31], a 30kW specialised configuration is manufactured wholly dependent on the available space for mounting and the cooling system adopted. The endplate is redesigned to

accommodate the power electronics and any extra cooling mechanism (cooling fins) added. This design aims to protect the power electronics by placing them before the motor in the



Fig. 3 Endplate mount integration. Redesigned finned endplate with Converter Loss Simulation Resistors [31] cooling air flow [31]. However, the machine suffers in this regard due to the redesigned end plate restricting adequate ventilation and cooling since all end winding losses must now be conducted radially. It is generally assumed that the machine robustness means it is able to withstand elevated temperatures compared to the converter.

In a very high speed machine it may be difficult to adequately ventilate the rotor if adopting this design. An extra cooling mechanism may be necessary if the IMD in question is operated at high torque and low voltage [31]. The power electronics position in [31] is necessary due to the available space in a predefined motor and the cooling system adopted. The power electronics unit was mounted on a redesigned endplate which was used as a heat sink for the power modules. Due to the lack of available space for mounting, a matrix converter was used in order to avoid the bulky energy storage elements and DC-link circuits used in traditional converter configurations [32]. The fan is redesigned (increased diameter) to compensate for the reduced air flow to the motor.

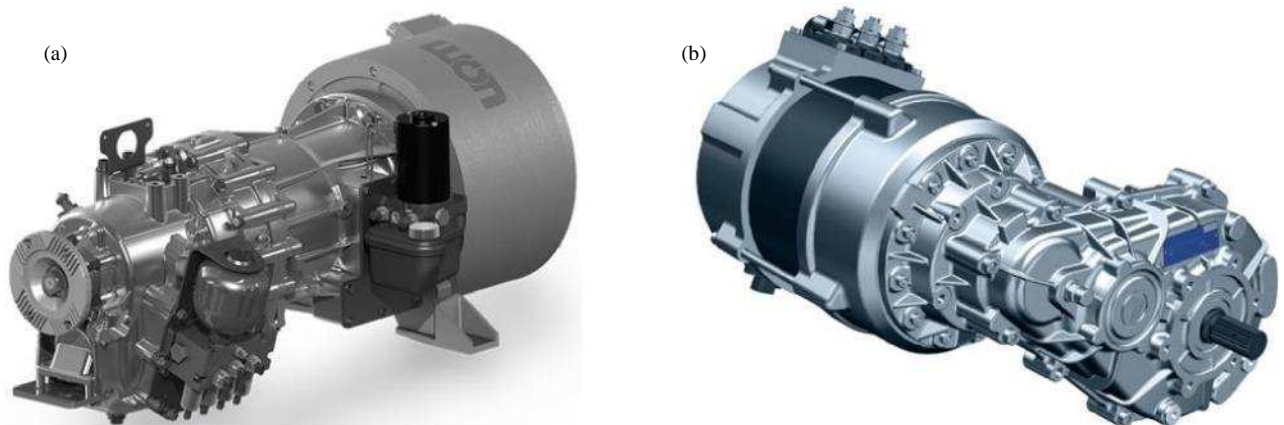

Fig. 4. (a) UQM PowerPhase HD 250 [33]. (b) Fig. 4. (b) Bonfiglioli Electric Power train 600D [34]

Commercial endplate mounted configurations include the UQM PowerPhase HD 250 with NexDrive EV3-850 [33] and Bonfiglioli Electric PowerTrain 600D [34]. Both IMDs are for electric vehicle applications with high power ratings of 250kW and 45kW respectively. Other manufacturers include TB Woods and ABB with a mid-range power rating portfolio between 3.7kW to 7.5kW [35], [36]. Typical applications include electric vehicles where surface integration is difficult due to lack of space in the radial direction.

2.3. Stator Iron Mount Integration

This configuration is aimed at producing a more compact, high power density IMD. The power converter is mounted on the stator back iron as shown in Fig. 5(a) [6]. This concept is particularly beneficial when the height of the converter components (especially the DC-link capacitor) is small. The converter can fit into the space between the stator back iron and endplate.

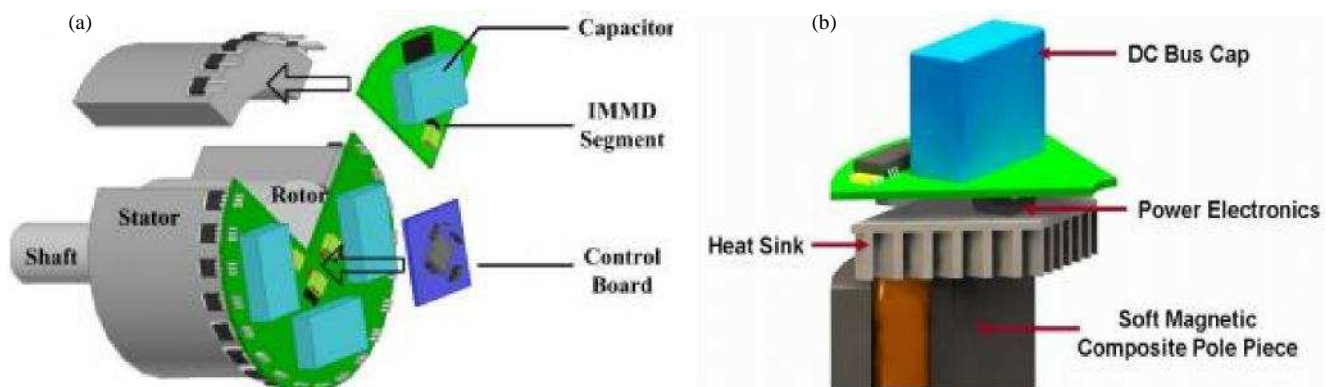

Fig 5 Back iron mount integration. (a). Power electronics mounted on Stator Back Iron [6]. (b) Stator pole module consisting of an iron pole piece and a power converter module [11].

The power converter may be segmented (modularised) around the back iron and the individual modules connected in series. The converter modules supply independent machine windings – akin to a Switched Reluctance Machine (SRM) method of energising the windings [6] or a concentrated winding. A similar design is utilised in [11] with the power converter also modularised. However, the use of Silicon based power electronics required the need for a heat sink in every module thereby increasing the overall volume of the module. The 83kW Protean Electric Wheel [37], [38] is one of the very few commercially available manufactured IMD adopting this approach. The benefits of having a more compact IMD due to the integration of the converter in the machine housing presents a few problems. The complexity of efficiently integrating the relatively fragile converter within the machine housing is amplified by the high vibration and shock loads the converter is subjected to in the machine enclosure [38]. The limited space within the enclosure, places the converter in close proximity to the windings. This requires careful thermal analysis to ensure the power electronics can withstand the

localised high temperature [39]. A liquid cooling system is adopted in [38] with an axial and orthogonal path to facilitate heat transfer and improve heat dissipation – cooling both the PE and windings simultaneously.

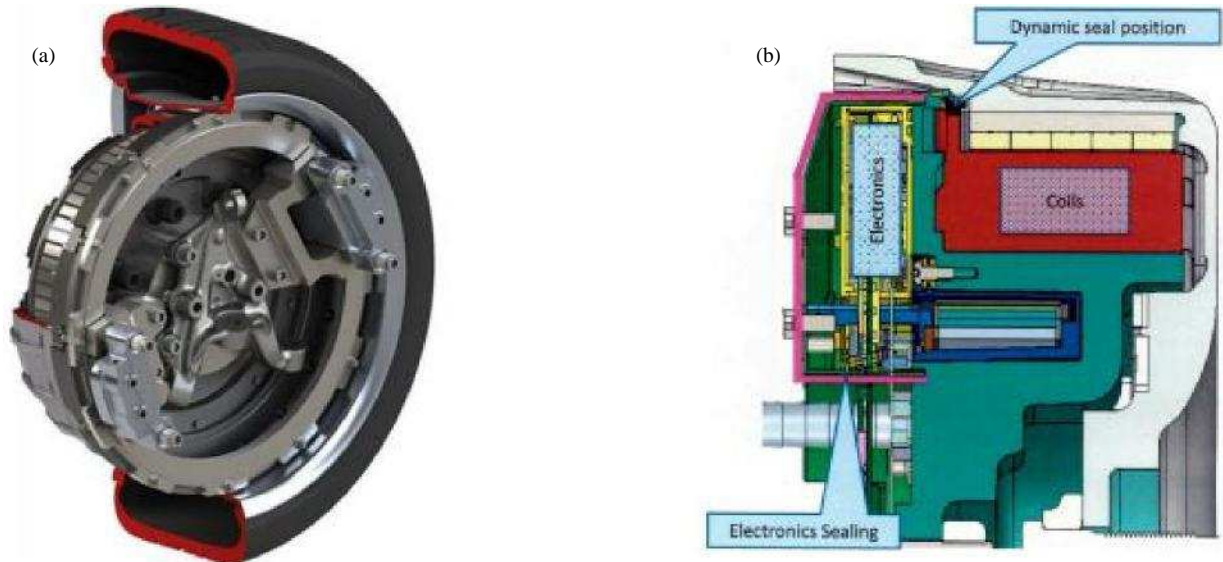

Fig. 6. (a) Unsprung assembly Protean in-wheel motor [37]. (b) Cross section of Protean in-wheel motor [38]

Table 1: Commercially available IMDs and their target applications

Company	Power rating (kW)	Mounting Position	Product	Application
Yaskawa	1.5-4	Surface	IE4MD [40]	-
Danfoss	0.5- 7.5	Surface	VLT FCM 300 [26]	Pumps, conveyors
Baldor	0.75-7.5	Surface	SmartMotor [41]	Fans
Lenze	7.5	Surface	8400 motec [29] [42]	Fans and pumps
Grundfoss	0.75- 22	Surface	Grundfoss E-pump [43]	Pump
VEM Group	0.5-30	Surface	VEMoDRIVE compact [27]	Pump
Rockwell Automation	1-1.4	Surface	Kinetix 6000M [44]	Food packaging
Leroy-Somer	5.5-7.5	Surface	VARMECA 14 [45]	Hoisting
Schneider	0.6 -2.2	Surface	Lexium 32i [25]	Materials processing
Sew-Eurodrive	0.37 - 4	Surface	MOVIMOT [46]	Packaging and conveyor systems
Lenze	Up to 11kW	Surface	Smart Motor M300 [47]	Materials processing
Siemens	30- 200	Surface	SIVETEC MRS/MRI [28]	Electric vehicles
Ford	45 – 70	Surface	Hybrid Escape [48]	Electric vehicles
Alpha	Up to 0.2	Endplate	ASX series [49]	-
INMOCO	0.05-0.3	Endplate	Pegasus Integrated Motion system [50]	Material processing

AXOR	0.3 – 1.47	Endplate	Fast Back [51]	Material Processing
TB Woods	0.75 – 3.7	Endplate	E-trAC IMD [35]	-
ABB	0.75-7.5	Endplate	Integral Motor [36]	Pump and fan
UQM	140-250	Endplate	Polyphase HD with NexDrive EV3-850 [33]	Electric Vehicles
Bonfiglioli	45	Endplate	Electric Powertrain 600D [34]	Electric Vehicles
Protean	83	Stator iron	Brabus E Class [37]	Electric Vehicle wheel

3. Cooling Systems

Close proximity integration demands power devices and modules capable of operating in harsh conditions, with elevated temperatures and thermal cycling – both active and passive. Various commercial products are unable to meet these demands and it is imperative an efficient cooling system is implemented. Cooling the integrated converter requires extensive thermal analysis of the converter and machine individually and as a unit. Adopting separate cooling systems for the converter and machine potentially increases the volume, cost and maintenance demands of the IMD.

In IMDs, the converter is mounted on or in the machine enclosure, this combines both thermal and mechanical requirements of these components into a single design problem. Combining the physical structure of both converter and machine into one housing reduces the physical size of the motor drive and reduces duplication. Adopting a unified cooling system instead of the traditional separated option tackles the thermal demands of both converter and machine simultaneously. However, since the thermal demands of the PE and machine vary (due to the large heat flux of the PE compared to the machine) a unified cooling system that efficiently accommodates both PE and machine is complicated [52]. The use of a combination of active and passive cooling systems is inevitable in modern IMDs due to the rigorous thermal demands of the system [53].

Using an active cooling system involves forced convection cooling of the power module and machine [54], [55]. This increases the overall weight and volume of the system whilst adversely impacting overall system performance. The substrate or base plate (heat spreader) of the converter is in direct contact with the coolant which increases the heat transfer coefficient between the converter and coolant aiding heat dissipation. The increased cost and added maintenance of the cooling system is also a drawback.

In most industrial drives and IMDs in literature, when a unified active cooling system is adopted the thermal path can be arranged in parallel or series. In a parallel path, both heat sources- the machine and PE are independent of each other. When implemented in an IMD where the heat sources are in close proximity, isolation is required. Isolation involves sectioning the power module away from heat sources in an environmentally controlled compartment but the closer the converter is to heat sources like the stator windings and iron, the harder it is to isolate [56]. This thermal path arrangement is implemented in [31], [57] with the more fragile PE is sectioned off from the machine by the redesigned end plate. Emphasis is on protecting the PE, as the machine is usually viewed as thermally ‘robust’ enough to handle elevated temperatures.

A series/unified path for the machine and converter offers a common path for heat flow. The thermal path is from the coolant to the PE then machine (or machine before PE). The varying thermal demands of both PE and machine and the large temperature gradient of the thermal

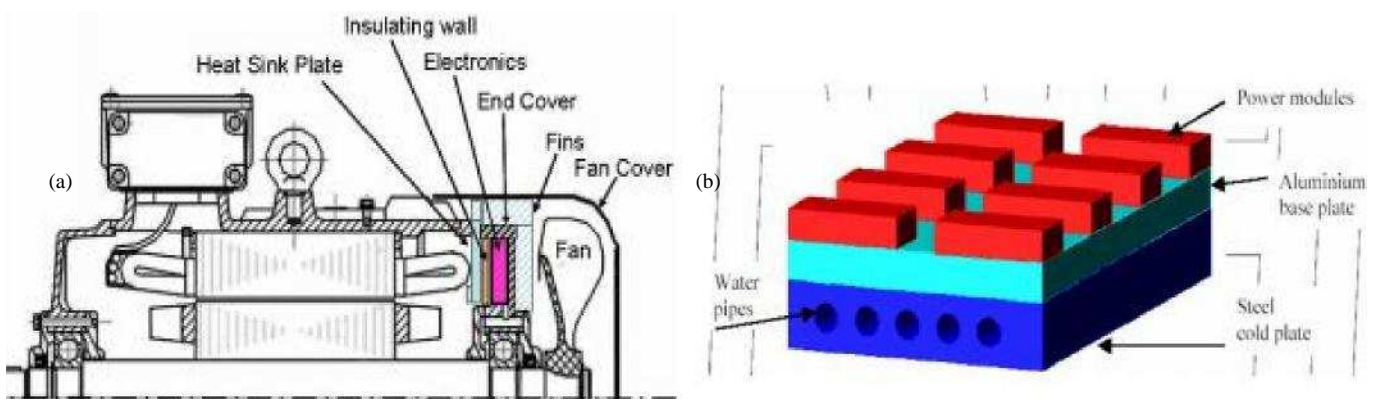

Fig 7: Showing parallel and series cooling paths (a) Axial View of PE mounted on Endplate – parallel path [31] (b) Simplified layout of water pipes through machine housing – series path [20]

path makes its implementation complicated. Most IMDs adopt either a fully parallel cooling path or a hybrid of both parallel and series cooling.

In [20] and [24], both converter and machine share a common thermal node for heat dissipation – the machine housing. Forced convection cooling using water pipes machined through the machine housing is incorporated. The drawback with this arrangement is the large pressure drops in the coolers and large temperature gradient that exists in the common thermal path due to the difference in thermal demands of heat sources. A series-parallel hybrid cooling system is adopted in [31], with the fan cooling the sectioned PE unit first before the rest of the machine.

In a passive cooling system, no external cooling system is utilised and heat dissipation is achieved through a combination of - natural convection, use of a thermal mass (heat sink), ventilation and thermal isolation. Thermal management using a passive cooling system can

also be achieved by reducing the overall power ratings of the system, utilising high temperature operating components and increasing efficiency - in order to reduce system losses.

Converter cooling ranges from a simple heat sink or heat spreader to an advanced convection cooling system. Heat sinks and spreaders offer a cheap and simple cooling option but as the required operating temperature of the IMD increases a more efficient cooling system is required. Heat sinks and spreaders are often large compared to the cooled devices. Novel cooling concepts have been proposed for IMD for improving heat transfer [53], [58-62].

In [53], [58], Danfoss presents an improvement on the standard jet impingement cooling system by removing the coolant from the thermal path before it starts to warm up. This eliminates the temperature inhomogeneity usually associated with a 'series path' cooling. A similar concept is adopted in [62] where an active cooling substrate for the PE is manufactured by machining a synthetic. In [59], a water-cooled, finned common node between the converter and machine is manufactured similar to [53]. The surface area of the common thermal path is

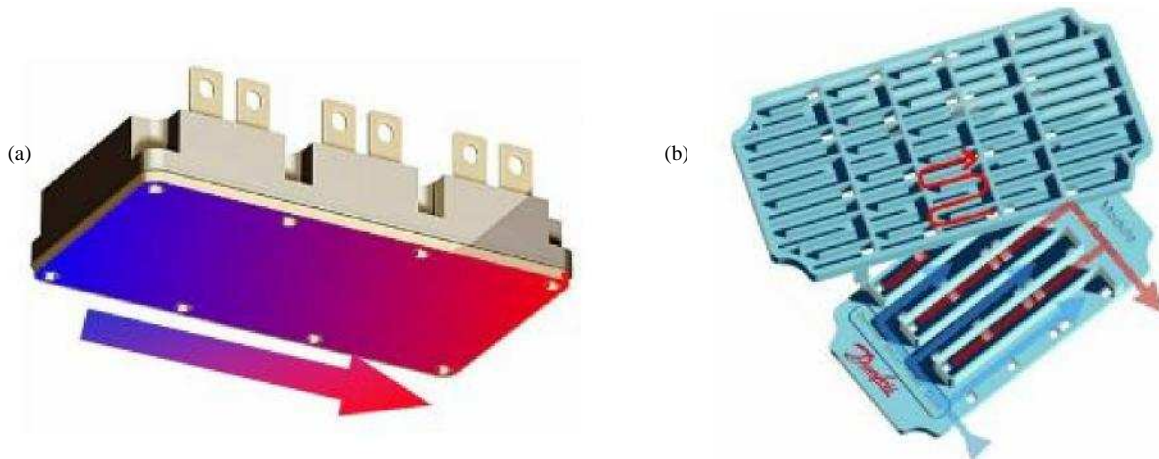

Fig. 8. (a) Temperature gradient in a standard cooling system (b) Danfoss Showerpower cooling concept showing the finned baseplate and vents for coolant input and output [53]

both increased and cooled, further reducing the temperature gradient of the common sink. Infineon presents a novel parallel cooling system in [61] for EV applications. The converter module is designed to provide optimum temperature dissipation from the module and isolation from the rest of the system. A combination of active and passive cooling approaches is utilised in [61] where the power device operating temperature is reduced and the power module is redesigned to allow liquid cooling between its mounting plates. These novel concepts are aimed at improving heat transfer in PE module.

A combination of forced convection (active) and passive cooling presents the only realistic cooling option for a power dense, closely integrated IMD system. This is due to the high heat transfer coefficient and low thermal resistance it offers aiding a more efficient cooling. Although low power systems will reduce thermal management demands in IMDs, close

proximity integration and the shift to high power applications in recently manufactured IMDs suggests low power systems do not offer a realistic solution to the problems encountered in close proximity integration. By utilising materials that can withstand high temperatures and harsh conditions, both active and passive cooling can be utilised without compromising on power ratings.

4. High temperature Devices

4.1. Wide Band Gap Materials

With increasing demand for more efficient, higher power and higher temperature operation of power electronic converters, the challenge of increasing the efficiency and power density of converters has become more urgent for design engineers to solve [63]. Presently, silicon power devices are the dominant semiconductor choice in industry [64], [65]. However, due to basic physical restrictions, silicon power devices have reached their limits in terms of further development and scaling [66]. They also have a maximum temperature for the device junction in the range of 125-150°C [66].

Wide band gap semiconductors have been championed as the future in semiconductor technology since the 1950s [67]. High temperature and low conduction & switching losses are some of the advantages of wide band gap semiconductors in power devices [68]. Their ability to operate at higher power densities, voltages and frequencies are also potential advantages that make them beneficial in power device applications.

Table 2: Material properties of Si, SiC, GaN and Diamond [69]

Property	Si	6H-SiC	4H-SiC	GaN	Diamond
Bandgap E_g (eV)	1.1	3.03	3.26	3.45	5.45
Dielectric Constant, ϵ_r	11.9	9.66	10.1	9	5.5
Breakdown Field, E_c (kV/cm)	300	2500	2200	2000	10000
Electron mobility, μ_n (cm^2/Vs)	1500	500	1000	2000	2200
Hole mobility μ_p (cm^2/Vs)	600	101	115	850	850
Thermal conductivity, χ (W/cmK)	1.5	4.9	4.9	1.3	22
Thermal Expansion ($\times 10^6$)/°K	2.6	3.8	4.2	5.6	1-2
Saturated E-Drift Velocity, V_{sat} ($\times 10^7$ cm/s)	1	2	2	2.2	2.7

Table 2 shows the material properties of the most common wide band gap semiconductors compared to silicon. The wide band gap semiconductor devices exhibit superior physical properties compared to silicon devices [70-74]. Diamond potentially exhibits much better

properties compared to SiC or GaN. However, there has been a lack of development due to financial cost of implementation, material availability and its low coefficient of thermal expansion (CTE) [75]. There are also significant manufacturing issues due to a lack of efficient methods to create conventional devices that rely on doped layers.

For packaging, it is essential that the CTE of the semiconductor material matches the electrically insulating ceramic board [76]. This allows the semiconductor material to be easily adapted for higher temperature applications. GaN and SiC are a technically and commercially realistic competitor for Si in the power semiconductor market compared to diamond and are becoming widely available [77-81].

4.2. Silicon Carbide vs Gallium Nitride

SiC and GaN are two important wide band gap materials for future switching and RF power applications. SiC and GaN both exhibit higher thermal conductivity and bandgap energy compared to Si [82]. With GaN's higher electron mobility compared to SiC and Si, GaN should ultimately be the best device to provide lower losses at higher frequencies [83]. High frequency operation allows for smaller parasitics, especially DC-DC capacitors. This leads to a reduction in the overall volume and increase in power density of an IMD incorporating GaN power devices.

The energy band gap of silicon carbide is lower than GaN. Since a larger band gap results in a smaller generation of carriers in the depletion regions of devices, it is favourable for reducing the leakage current of devices which utilize P-N junctions to support voltages. The larger band gap is also favourable for producing Metal-Semiconductor contacts with larger Schottky barrier heights. This means GaN in theory can produce thinner devices for a rated voltage compared to SiC [84]. For a given voltage rating both GaN and SiC will produce smaller devices compared to Si, making them highly beneficial for IMDs due to the limited space available for integration.

In power devices, the breakdown electric field strength determines how high the largest field in the material is before breakdown occurs. This allows SiC and GaN to operate at much higher voltages and lower leakage currents compared to Si. With SiC and GaN exhibiting significantly higher values compared to Si, higher power rated devices can be produced. This is particularly beneficial in IMDs where power density is important. SiC and GaN can produce smaller devices with higher power ratings compared to Si.

The maximum operational temperature of a semiconductor material is determined by the bandgap. The temperature limit is reached when the number of intrinsic carriers approaches the number of purposely added (extrinsic) carriers. Therefore, semiconductors with wider

bandgaps can operate at higher temperatures. In IMDs that demand operating temperatures higher than 150°C, SiC and GaN provide a realistic integration option since they can produce devices with a practical temperature limit of 600°C compared to Si with a temperature limit of 225°C [57].

The thermal conductivity of the material determines how quickly and efficiently it conducts heat to its surroundings [85], however, packaging limits restrict the overall maximum operating temperature. SiC has a higher thermal conductivity compared to GaN and so SiC can theoretically operate at higher power densities compared to GaN devices. Efficient heat dissipation is important in IMDs, especially the converter unit due to the high heat flux it produces over a small area (compared to the machine). By utilising SiC PE devices, the converter module temperature can be reduced further decreasing the overall IMD temperature.

Manufacturers argue that both devices do not overlap in competition but have distinct benefits for specific applications. GaN is thought to be the obvious choice for low voltage applications (<600V) and SiC better for high voltage applications (>1000V) [86]. However, between 600V-1000V the choice between SiC and GaN is application dependent.

SiC poses significant advantages over GaN in power device application due to a number of reasons. Some of them include [87-91] –

- The lack of native oxide in GaN restricts production of GaN MOS devices. However, SiC uses SiO₂ as a native oxide.
- GaN as a material possesses a lower thermal conductivity (about one-fourth) compared to SiC. For high power, high temperature operation applications, this is particularly important as heat needs to be dissipated quickly and efficiently.
- The cost of manufacturing pure GaN wafers due to the difficulty in growing GaN boules is higher than that of SiC. GaN wafers are usually grown on SiC or Sapphire. However, recently, GaN wafers are grown on Si producing potentially cheaper devices compared to SiC [88]. The epitaxial growth of GaN on the silicon wafer is the sole cost disadvantage.

5. Modular Integration

Modular integration involves segmenting the power electronics into smaller modules that control dedicated stator winding sections. These modules are physically independent of each other and are usually connected together in series or parallel for the purpose of control. An active voltage (or current if connected in parallel) balancer is usually required to balance and regulate the segment voltages during unbalanced or asymmetrical load conditions. Advantages

of modular systems include fault tolerance, better thermal capabilities, power rating scalability and a possible reduction in the overall size and cost of the PE.

Drive modularisation is independent of converter position as mounting can occur on the motor housing [22] on the stator iron [6], [10] or on the end plate [31]. Fault tolerance is one obvious advantage as multiple modules exist which form a unit as opposed to a centralised power electronics module. The system can be designed to allow for individual module failure. Current and voltage loading stress is also reduced in the PE as lower rated components are used in the modules to form a much larger rated unit [92].

The size of the components can also be reduced as the ratings for independent modules and their passive component sizes are a lot lower compared to a central PE unit.

Improved thermal capability is another possible advantage. This is as a result of having individual lower rated components and more evenly distributed heat dissipation [93].

Due to these potential benefits, modular drives are very beneficial for IMD design. In [6], both machine and drive are modularised (one converter phase leg per machine pole) and the benefits include – better thermal performance due to lower rated devices, increase in machine lifespan as a result of low voltage change in the slot insulation layer, lower maintenance cost and fault tolerance. A similar concept termed “site of action integration” is applied in [13] for EV integration with resulting benefits of shorter connecting wires. The possible drawbacks are the necessity for a complex control system for the individual power modules and the difficulty of mechanically and structurally integrating the modules with the motor [94].

6. Converter Topologies for IMD

Power electronic converter configurations and topologies have been analysed extensively in [95]. The topologies analysed include;

- 3 phase buck converter
- Vienna Rectifier
- Discontinuous Conduction-Mode (DCM) boost converter
- Continuous Conduction-Mode (CCM) boost converter
- Matrix converter
- Two-stage Direct Power Converter (DPC) with Reverse Blocking (RB)-IGBTs in the rectification stage

As the results of converter topology comparison are application-dependant, it is not possible to determine a single best topology for any IMD. The pros and cons of each topology are investigated below, focusing mainly on aspects more related to possible integration.

6.1. Matrix Converter

The matrix converter is a forced commutated direct ac-ac converter that uses an array of nine controlled bidirectional switches as the main power elements to create a variable output voltage system with unrestricted frequency [32]. The conceptual scheme of a matrix converter is depicted in Fig. 9.

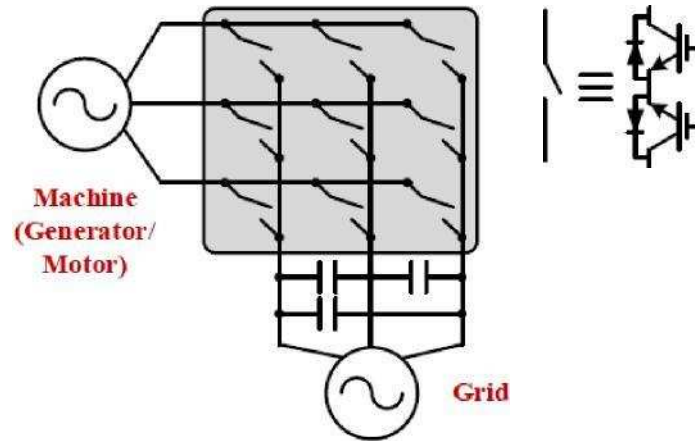

Fig. 9. Matrix converter

The potential advantages of this topology include a relatively compact size (no need for dc-link capacitors), sinusoidal input current, bi-directional power flow (power regeneration capability) and a controllable input power factor [32]. It is an attractive prospect in applications where volume, reliability and weight are important – particularly in IMDs.

Its main disadvantages are a low voltage transfer ratio of 0.86, the necessity of an additional clamping circuit for protection and of a mainly capacitive input filter. Moreover, it suffers from high cost due to the large amount of switching devices (18 IGBTs and 18 diodes) and due to the non-conventional arrangement requiring custom made power modules. The absence of a dc-link capacitor means no decoupling between the input and output, and also the complete absence of ride-through capabilities [96].

6.2. 2-Level Full Bridge Converter

The 2-Level full bridge topology is the workhorse of Power Electronics as we know it. It is a very well-known structure (Fig. 10), relatively simple to drive and flexibly controllable with different algorithms to suit the application. It can be used in both inverter and rectifier mode (bidirectional power flow). Being so common, power modules with this arrangement are easily available on the market, with power ratings ranging from a few hundred Watts to MWs, and both based on Si (MOSFETs and IGBTs) and SiC technologies (MOSFETs and JFETs), thus a custom designed power module is not required.

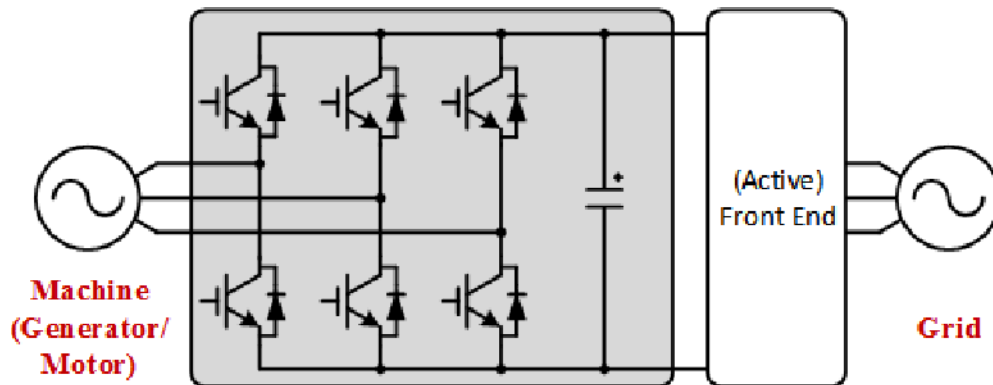

Fig 10. 2-Level full bridge converter

A drawback of this topology when compared to multi-level topologies (as will be described below) is the relatively higher current THD, even when operated in PWM. The level of the THD and its impact is electrical machine dependent and hence this needs assessing for any given machine.

6.3. 3-level NPC converter

The 3-Level Neutral Point Clamped (NPC) topology is probably the most known of the 3-Level AC/DC converter topologies and it is gaining strong industrial acceptance. The main benefit of using a multilevel converter structure is the reduced current THD which can be achieved when compared to conventional 2-Level structure operated at the same switching frequencies. This will naturally lead to higher achievable fundamental frequencies making this configuration desirable for high speed applications. Additional benefits in terms of conversion efficiency gains may occur if the converter is designed such that lower voltage rating devices are used, which in turn would lead to reduced switching losses. A reduction in the current THD is also closely related to a reduction in machine losses, and can potentially ease the IMD overall thermal management.

The main drawbacks of this arrangement is the necessity to balance the DC-Link midpoint (using relatively complex control algorithms) and the high number of active devices, resulting in a lower reliability, added complexity and an increased cost. As this topology is gaining popularity for a range of energy conversion applications including automotive and industrial, there is a reasonable selection of commercially available power modules for this topology. The structure of the 3-Level NPC full bridge is depicted in Fig 11.

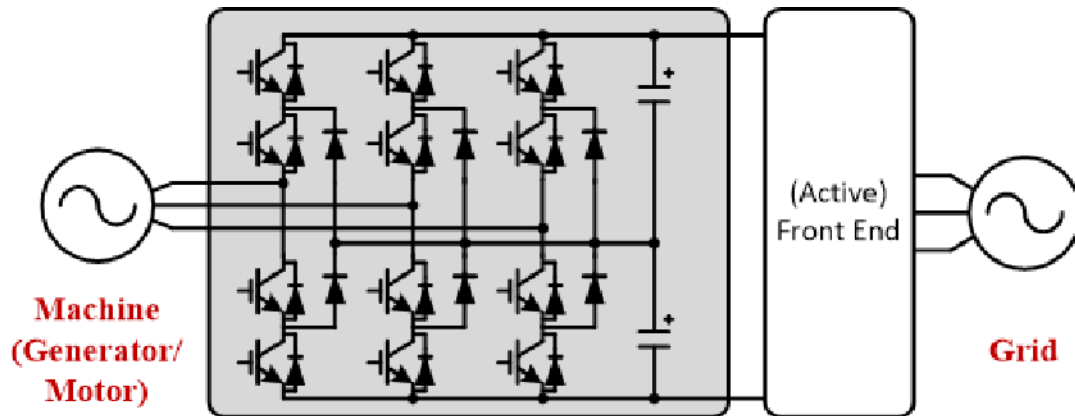

Fig 11. 3-Level NPC full bridge

converter 6.4. *Multiphase Full Bridge converter*

Multiphase Full Bridge topology (Fig. 12) is derived from the conventional Full Bridge arrangement. With respect to this it presents a potentially more complex control algorithm (depending on machine windings arrangement and number), however it also presents a number of advantages such as increased fault tolerance as well as increased power processing partitioning (feature highly desirable in an IMD). As Full Bridge converters, Multiphase Full Bridges can be used in both inverter and rectifier mode (bidirectional power flow) and suffers from the same drawbacks. The same considerations can be made for power electronics modules and technologies.

The number of phases in electrical drives is typically 3, driven partly by convention and partly by a compromise between number of devices and machine utilisation. 3 phases represent the best compromise between the two in most conventional scenarios. The following are some considerations whilst selecting the number of phases:

- Single phase: this represents a very cheap converter solution however the machine is typically characterised by very high torque ripple, vibration and losses. This is due to the inability of establishing a rotating field in the machine.
- Two phase: a two phase drive can be fully functional and effective when compared to 3 and higher phase number alternatives as in all cases a rotating field can be established. It can be a suitable solution for high speed drives especially for cost-sensitive applications without high torque requirements. The downside of such a drive is the typically lower torque density of the machine and higher torque ripple.
- 4-phase and higher: will present a solution with an improved torque density and lower torque ripple when compared to 3 phase machine drives. However, this comes at the extra cost of having more components. Higher phase numbers are however attractive when high power drives are to be connected to low voltage networks such in automotive applications.

Channelling the power through more phases limits the current requirements of devices and thus their size, allowing for an easier structural integration into the machine, as well for more spatially distributed power electronics-related losses.

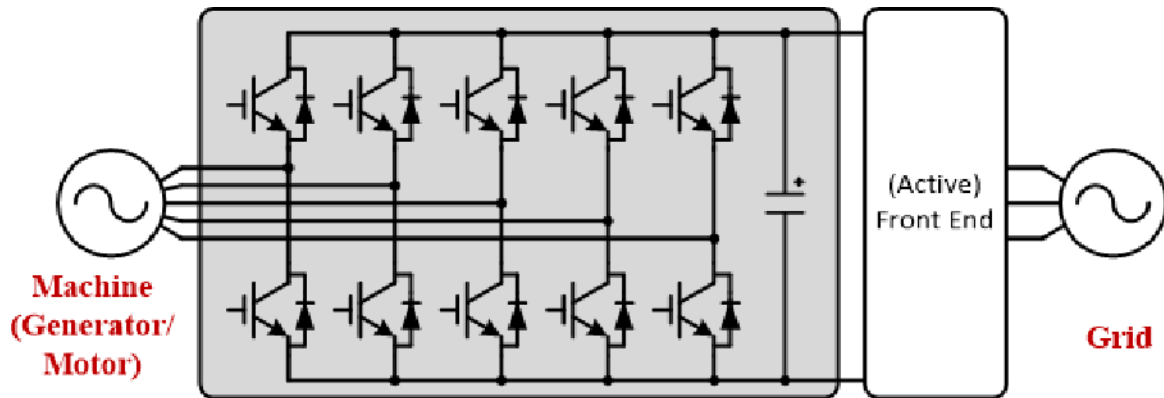

Fig 12. Multiphase full bridge converter

7. Passive Components

Passive components (especially capacitors) account for a considerable amount of the material cost and volume of a power electronic system. Figure 13 gives a graphical illustration of the material costs and volume of passive components compared to other components in a power electronics system. At high temperatures capacitors are particularly challenging due to thermal limits of many common capacitor materials. Leakage currents also occur at high temperatures making it hard for the capacitor to hold charge [57].

The DC link capacitor helps avoid over-voltage during commutation and provides a low impedance path for the switching harmonics, effectively buffering the ripple current, but passive DC-link capacitors are often bulky and expensive.

There are four main capacitor technologies available -

- Multi-Layer Ceramic Capacitors (MLCC)
- Electrolytic Capacitors
- Film Capacitors
- Electro-Chemical Double Layer (ECDL)

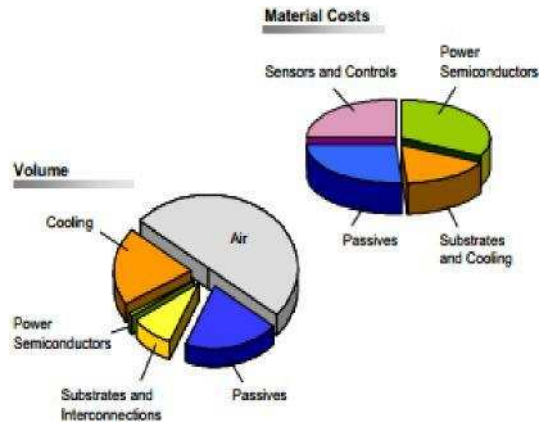

Figure 13: Typical Material Cost and Volume Distribution in Power Electronics System [13]

7.1. Ceramic Capacitors

The Multi-layer Ceramic Capacitor (MLCC) is the most dominant form of ceramic capacitor. Its most important attributes are its high capacitance and compactness [97-99]. The most expensive of the four capacitor options, ceramic capacitors offer very high AC current ratings, high temperature operation (up to 200°C) and small size. It is also the most widely used passive component in modern electronics [100] and has high energy density.

Ceramic capacitors are not limited to MLCCs. Bespoke capacitors exist with unique capabilities lacking in other capacitor technologies [100]. High temperature ceramic capacitors that can withstand temperatures of up to 250°C exist [101]. Ceramic capacitors are used mostly for high temperature and high voltage applications [102]. The major disadvantages are the high cost and the brittle nature of ceramic capacitors [103], [104]. In IMD traction applications where shock and vibration is prominent, reliability issues arise over the mechanical stability of ceramic capacitors. Also, the low energy density of ceramic capacitors mean several components have to be paralleled up to achieve the necessary ratings required. This further increases the overall cost of the IMD system.

7.2. Electrolytic Capacitors

These capacitors are mostly used in the rectification stage of switched mode power supplies (SMPS) [105]. The cheapest and most popular of the four options, electrolytic capacitors achieve the highest storage densities (up to 1 J/cm³) but have the lowest AC current ratings. Operating temperature is usually up to 120°C [106]. Although electrolytic capacitors are the standard choice for dc link storage in conventional motor drives, their limited current handling capabilities and operating temperature restricts their use in integrated drives. Additionally, due to their physical construction, they show a relatively high equivalent series resistance (ESR)

and equivalent series inductance (ESL), thus posing a limit at the converter maximum switching frequency of operation. The thermal limitation is a problem especially in IMDs due to the compact nature of the unit.

Theoretically the maximum voltage for electrolytic capacitors is 800V. However, practically the maximum voltage is 600V [107]. This makes electrolytic capacitors susceptible to voltage surges. Electrolytic capacitors are also polarity dependent thus restricting their applications to DC circuits.

Thermal degradation of the electrolytic capacitor is a heat triggered electrochemical reaction [108], [109]. Thermal degradation causes a relatively short life time of electrolytic capacitors compared to ceramic and film capacitors [110]. Although electrolytic capacitors have very high energy densities, In IMD integration, their bulky size and short life time due to thermal degradation means they hardly feature as passive components. This is due to the high operating temperatures and limited integration space in the IMD enclosure.

7.3. Film Capacitors

Polymer Film Capacitors are the most flexible in device geometry of the aforementioned capacitor technologies. They combine the advantages of low losses and mechanical robustness with high volume capacitance. They are also polarity independent providing true bipolar operation. Typical applications include high frequency inverters and solid state switch snubbers. They are also capable of operating at higher voltages (up to 100kV) [111]. Their ability to work under high electric field coupled with their high energy density is an advantage [112], [113]. Theoretical operating temperatures can reach up to 220°C, however, commercially available film capacitors operate at temperatures up to 170°C [114]. They also exhibit higher life time and higher ripple current capability compared to electrolytic capacitors [115].

Their main disadvantages include their high cost, lower capacitance per volume compared to electrolytic capacitors and low-medium operating temperatures. Despite these disadvantages, film capacitors offer a realistic capacitor choice in IMDs due to its small size and longer life time compared to electrolytic capacitors and its mechanical robustness and high energy storage density compared to ceramic capacitors.

7.4. Electro Chemical Double Layer (ECDL)

Chemical Double Layer capacitors also known as ‘supercapacitors’ are low energy (compared with electrochemical batteries), high power density storage devices [116]. Although not as prominent as the aforementioned types of capacitors, they have been commercially

available for decades [117]. Typical applications include backup and recovery systems and as energy storage for electric vehicles [118].

The relatively high cost [119] and high self-discharging rate [120] are potential drawbacks of the ECDL. Its low operating temperatures compared to other types of capacitor also makes ECDL capacitors unlikely to see successful application in IMD. They also have a very low operating voltage per cell which means that large numbers of cells connected in series are required as well as complex balancing circuits to ensure that the cell voltages remain equalised throughout the stack [121].

8. Packaging of Power Electronics Module

In an IMD, the converter is arguably the most sensitive component in the system. The growing demand for an efficient, high temperature operable converter has led to advancement in research on wide band gap devices [122]. High temperature environments like combustion engines in aircraft and automobiles could benefit from a high temperature integrated power module. The ability for a power module to operate at a high temperature results in a smaller system size of the IMD and reduced costs of the cooling system.

Wide band gap devices like SiC and GaN can theoretically operate at temperatures above 500°C while Si is restricted to junction temperatures lower than 175°C [123-125]. Above 200°C Si devices experience latch-up at reverse bias junctions and leakages [57]. SiC power devices exist with operating temperatures up to 200°C [126-129], but the maximum temperature of a SiC power module for example is limited to about 150°C [130], [131]. A commercial high temperature SiC module has been reported operating at 250°C [132]; however, reservations exist over its reliability above 200°C.

The packaging of the power electronics module primarily restricts its maximum operating temperature [133], [134]. The module undergoes high thermal and thermo-mechanical stresses at high temperatures leading to critical failures in the system [135], [136]. Degradation of polymeric materials used in the module packaging as well as the creation of intermetallic compounds, which may weaken the joints also occur at high temperatures [124], [137] and [138]. Categories of interest in power module packaging are – Interconnects, Die Attachment, Substrate choice and Encapsulation [139].

8.1. Interconnects

Conventional power modules use aluminium, copper or gold wire bonds as the main current path for interconnection [140], [141] and the wire bond is arguably the weakest part of the power module [142], [143].

At temperatures above 200°C, the reliability and mechanical stability of aluminium bonds is drastically reduced [87], [142] with wire bond lift-off or wire bond breakages the most common failures [144]. These failures usually occur at the heel of the wire bond – where the most stress occurs [145], [146]. The thermal resistance of the wire bonds also increase at high currents and temperatures [61], [147].

Alternative interconnect options that offer high temperature operation and reliability over 200°C will improve the life time of PE modules in IMDs. Large diameter platinum wires have been investigated for high temperature application integration. Despite exhibiting exceptional mechanical strength at high temperatures, CTE mismatch with the semiconductor and low electric conductivity are some of its disadvantages [148]. Silver alloy wire bonds have also been investigated for high temperature operation [149]. Its high thermal conductivity is also beneficial in IMD applications [150]. Flip chip technology can also potentially replace standard interconnections by connecting the power devices directly to the package through conductive metallic bumps [151]. In [152], a highly power dense, wireless converter module for IMD integration is presented using Flip Chip on Flex (FCOC) technology with improved thermal performance.

8.2. Die Attachment

The die attachment is the connecting interface between the substrate and the die ensuring that the die is mechanically stable on the substrate and thermally efficient in heat transfer to the substrate [153].

Materials used for die attachment ranges from high lead and lead free solders to silver sintered layers [154-158]. Solders are the most common die attachment but often have a low working temperature. However, Sn based solder alloys have been reported to possess working temperatures more than 280°C [159-161]. However, its low thermal conductivity restricts efficient heat transfer in power modules. Zinc alloy solders have also been reported to operate at temperatures above 200°C [162].

Sintering offers the best die attachment option boasting working temperatures up to 650°C and thermal conductivity orders of magnitude higher than solder [163-167], properties particularly beneficial for IMD integration. However, a very high pressure (around 30 MPa) is required to achieve sintering leading to potential cracks or possible destruction of the relatively fragile ceramic substrate. Silver particle pressure-less bonding has been reported in literature and provides an alternative for silver sintering without the substrate subjected to high pressures [168].

8.3. Encapsulant

The encapsulant acts as a protective barrier for the power chip and components from hostile environments. It also acts as a heat spreader and can prevent arcing at high voltages [169] [170]. In close proximity drive integration (like back iron mount integration), the PE encapsulant will be subjected to high ambient and operating temperatures. It is therefore important the chosen encapsulant can withstand such high temperatures and harsh environment. Typical encapsulation materials are Silicone gel, Epoxy and Parylene with the later showing high working temperatures more than 200°C. Several encapsulants claim to have working temperatures more than 250°C [171-181]; however, reliability studies claim encapsulants slowly degrade before reaching 250°C [137], [182].

8.4. Substrate

The substrate provides electrical isolation, mechanical support and thermal conductivity for the circuitry of the power module. It consists of a thin ceramic substrate sandwiched between two layers of copper or aluminium metallisation. Popular ceramic materials are – Alumina, Aluminium Nitride, Silicon Nitride and Beryllia. Alumina is the cheapest and most common option but has the lowest thermal conductivity compared to others [183], [184]. Aluminium Nitride (AlN) possesses a higher thermal conductivity and its coefficient of thermal expansion (CTE) matches SiC [185], [186]. However, its mechanical strength is poor [187]. Beryllia although exhibiting an excellent thermal conductivity is a toxic material raising health and environmental issues. Silicon Nitride (Si₃N₄) is fairly new hence its limited supply. It has average thermal and electrical characteristics but excellent mechanical properties.

In IMD integration, high mechanical strength, high thermal conductivity and a close CTE to the power devices utilised are some of the properties required. The choice between Si₃N₄ and AlN is application dependent with AlN used for a power dense IMD where efficient heat dissipation is paramount. In applications with high vibration levels (close proximity integration applications), Si₃N₄ is a better option for IMD integration with fracture toughness levels twice AlN's [140].

Other packaging technologies have been investigated in search of a more compact high temperature operation. Flip chip technologies present a compact wireless configuration [188-190] but reservations exist over its mechanical stability and mechanical stress at high temperatures [143], [191]. Flip chip on Flex substrates [192] have also been reported to reduce stress between solder joints, devices and substrates. Flex substrates also provide the flexibility of producing power modules with distinct shapes especially beneficial in IMD integration due to the lack of available mounting space [193]. Another wireless packaging technique – a variant of FCOC, utilising a “SKiN” flex layer is presented in [194] promising improved thermal

capabilities and power density compared to a standard power converter. Pressure contact technology has also been investigated as a possible replacement for aluminium wire bonds for high temperature applications [195], [196]. Its high manufacturing costs and complicated manufacturing process remain drawbacks in manufacturing. Careful selection of materials in the module is also important to avoid coefficient of thermal expansion (CTE) mismatch. CTE mismatch can lead to die fracture, fatigue and lifting, horizontal crack propagation, delamination and cracking of the ceramic substrate [57], [197] and [198].

The thermal and mechanical properties of a standard PE module components will limit its successful integration in a machine. Manufacturing a specialised power module by utilising WBG devices like SiC and GaN with high temperature operating die attaches, encapsulants and interconnects will aid successful close proximity integration. Also, adopting specialised packaging techniques like Flip Chip on Flex (FCOC) and “slot-module” [94] can improve power density and heat dissipation in the power module.

9. Challenges in IMD Design

The emphasis on smaller, more efficient and power dense converters has led to rapid development in converter technologies. Devices able to switch at higher frequencies allow for a reduction in size of power devices like magnetics and capacitors. Compared to the machine, the converter has a much higher power density with typical heat flux densities in the range of 50-500W/cm² for power semiconductor devices, compared to 0.1-3W/cm² for magnetic components and less than 0.1W/cm² for capacitors [199]. This is due to its smaller volume and high power handling capabilities [200].

The converter losses are concentrated over a smaller area leading to localised high temperatures (hot spots). This leads to complications in converter cooling and thermal management especially in close proximity to other heat sources such as stator windings [201]. Losses in the machine frame also increase the overall temperature of the IMD system. This limits the power dissipated by the converter, consequently decreasing its power handling capabilities [202].

Poor thermal contact between the converter baseplate or substrate and the mounting position could potentially be problematic depending on the quality of both surfaces [20], [24]. A poor thermal contact between both surfaces will increase the thermal resistance and cause poor heat transfer between the converter and machine. This is particularly troublesome when a singular cooling system is adopted in the IMD as the housing area is used as a heat sink for the converter and efficient heat transfer between the machine and PE is important.

The complexity and cost of installing a cooling system to efficiently dissipate heat from the converter and machine is also challenging.

Vibration and mechanical stability also pose reliability issues in drive integration. Machines that operate in hostile environments such as traction applications are exposed to high shock and vibration levels. Mounting the converter on or in the housing of these machines exposes the converter to significant vibration problems [6], [22]. Reliability of attachment methods such as thermal-joint compounds and screws may be severely affected by high vibration levels [22].

To tackle the pressing thermal and mechanical issues encountered in IMD design, future research in the following options should be considered -

- Advancements and efficient implementation of an active cooling system
- Manufacture of bespoke modularised converters
- Utilising high temperature devices

Future research into these topics will help adapt the cooling system, converter and machine components to the rigorous thermal and mechanical demands of an IMD system.

10. Future trends

Major challenges associated with power electronics integration include limited available installation space, high thermal and mechanical stresses on devices and machine components and the complex cooling systems needed. Current IMDs are as a result of a pre-defined converter installation space on or around the machine housing, usually as a result of the mechanical requirements of the machine, with little to no consideration on the converter needs. Increasing the power density, reliability and efficiency of IMDs whilst reducing the overall manufacturing cost has led to active research and development of smaller, more efficient power modules.

By exploiting the benefits of wide band gap devices, manufacturers have been able to produce devices that can withstand the rigorous thermal, mechanical and electrical demands of close coupling integration. GaN and SiC are expected to phase out Si as choice semiconductors in IMD applications. Compared to GaN, SiC has a distinct time and technology advantage in discreet power devices and module commercialisation and is expected to feature in future IMDs as the choice converter module or power device. ‘Full’ SiC power modules already exist providing high efficiency, temperature operation and power density whilst maintaining a small volume for machine integration. However, with GaN’s ability to operate at higher frequencies compared to SiC and ongoing research in cheaper alternatives on growing GaN boules, GaN is expected to compete fiercely in power device manufacturing with SiC. Diamond although

exhibiting superior properties compared to SiC or GaN is still decades away from commercialisation and is not expected to feature in PE modules in the near future.

Advancements in passives technology has also led to smaller high temperature operation devices with ceramic capacitors exhibiting operating temperature greater than 200°C. It is expected that the compactness, high capacitance and thermal capabilities of the ceramic and film capacitors will see them feature heavily in IMD converter modules in future. Aluminium Nitride is expected to remain the choice ceramic for power modules, however, research into Silicon Nitride (Si_3N_4) which possesses better mechanical properties should provide competition for AlN in the next few years. Currently, the copper layer on the ceramic substrate is usually nickel and/or gold plated in order to avoid oxidation of the copper layer. However, at very high temperatures (above 400°C) breakdown of this oxidation layer occurs – compromising reliability [187]. Extensive ongoing research into alternate finish materials like Titanium, Lead and Molybdenum could offer realistic alternatives to gold and nickel finishes.

These advancements in material and packaging technologies have led to more production of commercial high power IMDs. This suggests the 7.5 kW limit previously recognised as the threshold practical power rating of commercial IMDs has increased and will continue to do so. A shift from low/mid power rated IMDs to high power rated IMDs is also expected as WBG devices, improved component materials and better packaging techniques are properly incorporated in power modules and IMDs. Also recently manufactured IMDs suggest a shift from the popular surface mount configuration to a closer proximity integration with the converter integrated in the machine housing. Bespoke modular converter units enable close proximity integration and will see an increase in more power dense IMDs manufactured.

Typical IMD applications include pump and fans, however, high power rated IMDs capable of high temperature operation currently feature heavily in EV and HEV application. It is expected that IMDs will continue to feature in electric vehicular systems especially “under-the-hood” and motor tire environments where limited space and high operating temperatures exist.

11. Conclusion

In this paper, existing IMD technologies are presented. IMDs offer a more efficient, power dense option compared to a conventional machine and converter. The mounting position of the converter is wholly dependent on the available space in the machine housing, the target application and the cooling system adopted.

Wide band gap devices like SiC and GaN provide a realistic option for IMDs by offering a more compact and efficient converter capable of high temperature operation. However, the packaging of these power modules hinders exploiting their full potential.

Modularisation of the converter into smaller units will also help reduce the thermal stress on the devices and efficiently utilise available space around the machine housing. It will also help adapt the converter into the small confines of the machine housing.

Forced convection cooling and advanced packaging techniques allow the converter efficiently dissipate heat. This potentially allows close integration of the converter with the machine and a singular cooling system for the IMD.

Development of converter technologies, more efficient and robust passive components (especially capacitors), increased reliability, better packaging and semiconductor materials such as silicon carbide (SiC) and gallium nitride (GaN) will enable power electronics to meet the harsh and rigorous environmental conditions the converter faces in an IMD.

IMD design should involve a holistic analysis of the thermal, mechanical and electrical effects of the IMD components and the cooling system as a single unit. Manufacture of more mid and high power rated IMDs is expected with advancements in material and packaging techniques. Industrial applications like EVs & HEVs and material processing will benefit from high power density IMDs.

Co-manufacturing issues may arise over the production of IMDs since the manufacture of converters and machines are often very different. Machines manufacturers may view IMD design from a machines' perspective and vice versa for converter manufacturers. This raises the question of who designs an efficient IMD – PE or machines manufacturers? Since in reality both machine and PE modules are produced by different manufacturers, creating highly adaptable modular PE units and machine will aid IMD production. It is imperative both machine and converter are designed around the requirements each component has both individually and as part of a system.

REFERENCES

- [1] Bartos F. J., "Combination motors and drives move to make their mark" Control Engineering Online, December 2000, <http://www.csemag.com/single-article/combination-motors-and-drives-move-to-make-their-mark/d9a8ab08897749f02e39653c06a6cc49.html>
- [2] Bartos, F.J., "Integrated Motor-Drives Seek Wider Market, User Acceptance," Control Engineering, pp. 19-23, December 2000.

- [3] Viorel. I. A., Szabo. L., Ciorba. R. C., "Integrated motor and control unit for industrial variable speed drive" Accessed November 2015
<http://citeseerx.ist.psu.edu/viewdoc/download?doi=10.1.1.301.2182&rep=rep1&type=pdf>
- [4] Hornberger J. M, Cilio E., Schupbach R. M., et al, "A high-temperature multichip power module (MCPM) inverter utilizing silicon carbide (SiC) and silicon on insulator (SoI) electronics", Power Electronics Specialists Conference PESC, 2006, pp. 1-7
- [5] Babb M., Bartos F., "Integrated motor drive combinations," Control Engineering Europe, **57**, (21), 2001. pp. 66
- [6] Wang J., Li Y., Han Y., "Evaluation and design for an integrated modular motor drive (IMMD) with GaN devices", Energy Conversion Congress and Exposition (ECCE), 2013. IET, pp. 4318 – 4325
- [7] Agarwald S. H., Ryu S. H., Krishnaswami S., et al., "a review of high power, high temperature SiC devices", High Temperature Electronics Conference HITEC 2006, May 2006.
- [8] Williamson S., Jackson D.C., "Integrated drives for industrial applications", Proc. of PCIM'99, Intelligent Motion, pp. 9-13, 1999.
- [9] Thøgersen P., Blaabjerg F., "Adjustable speed drives in the next decade. The next step in industry and academia", Proc. of PCIM '00, Intelligent Motion, pp.95-104
- [10] Vas P., Dury W., "Electrical machines and drives: present and future", in Proc. of Electrotechnical Conference (MELECON '96), **1**, pp. 67-74
- [11] Brown N. R., Jahns T. M., Lorenz R. D., "Development of a converter for an integrated modular motor drive", Centre for Power Electronics Systems (CPES) 2007. CPES, pp. 419-425
- [12] Nie Z., Emadi A., "Integrated converters for switched reluctance motor drives", Power Electronics and Motion Control Conference, 2004. IPERC 2004, **2**, pp. 487 – 490.
- [13] Marz M., Schletz A., Eckardt B., Egelkraut S., Rauh H., "Power electronics system integration for electric and hybrid vehicles", Integrated Power Electronics Systems (CIPS), 2010 6th International Conference IEEE. pp. 1-10
- [14] Mohammed O. A., Liu S., Liu Z., "Physical modelling of pm synchronous motors for integrated coupling with machine drives", IEEE Transactions on Magnetics, 2005. **41**, (5), IEEE. pp. 1628 – 1631
- [15] Zeng L., Chen X., Nong X., San X., "FE-based physical model of LPMBDCM for integrated motor drive system analysis", Innovative Computing Information and Control, 2008. ICICIC '08. 3rd International Conference. IEEE. p. 581
- [16] Klumpner C., Nielsen P., Boldea I., et al., "A new matrix converter motor (MCM) for industry applications", IEEE Trans. on Industrial Electronics, 2002. **49**, pp. 325-335
- [17] Haghbin S., Khan K., Zhao S., et al., "An integrated 20-kW motor drive and isolated battery charger for plug-in vehicles", IEEE Transactions on Power Electronics, **28**, (8), 2013. pp. 4013 – 4029
- [18] Haghbin S., Thiringer T., Carlson O., "An integrated split-phase dual-inverter permanent magnet motor drive and battery charger for grid-connected electric or hybrid vehicles", 20th International Conference on Electrical Machines (ICEM). 2012. IEEE. pp. 1941 – 1947
- [19] Pickering S., Thovex F., Wheeler P., et al., "Thermal design of an integrated motor drive", IECON 2006 - 32nd Annual Conference on Industrial Electronics. IEEE. pp. 4794 – 4799

- [20] Tenconi A., Profumo F., Bauer S. E., et al., "Temperatures evaluation in an integrated motor drive for traction applications", IEEE Transactions on Industrial Electronics, 2008. **55**, (10), IEEE. pp. 3619 – 3626
- [21] Wolmarans J. J., Gerber M. B., Polinder H., et al., "A 50kW integrated fault tolerant permanent magnet machine and motor drive". IEEE Power Electronics Specialists Conference 2008. IEEE. pp. 345 – 351
- [22] Biswas P. S., Das N., Biswas S. K., "Design consideration of an integrated induction motor drive to replace auxiliary dc motors in locomotives", International Conference on Power Electronics and Drives Systems 2005. **2**. IEEE. pp. 872 – 875
- [23] Shakweh Y., Owen G.H., Hall D.J., et al., "Plug and play integrated motor drives," in Proc. of IEE Power Electronics, Machines and Drives Conference (PEMD'02), 2002. pp. 655-661
- [24] Farina, F.; Rossi, D.; Tenconi, A.; Profumo, F.; Bauer, S.E., "Thermal design of integrated motor drives for traction applications," Power Electronics and European Applications, 2005, pp.10.
- [25] 'Schneider Lexium 32i' http://download.schneider-electric.com/files?p_Reference=0198441113956-EN&p_EnDocType=User%20guide&p_File_Id=681840597&p_File_Name=LXM32iECT_Manual_V100_EN.pdf, Accessed November 2015.
- [26] 'Danfoss VLT DriveMotor FCM 300' http://www.danfoss.com/NR/rdonlyres/40FA1C95-CFB6-4BA1-A69D-D36F61436B59/0/FCM300_FactSheet_PF009A02.pdf, Accessed November 2015.
- [27] 'VEMoDRIVE variable speed drives' http://www.vem-group.com/fileadmin/content/pdf/Download/Brosch%C3%BCren/Flyer_VEM-motors/28_PB_en.pdf, Accessed November 2015.
- [28] 'Innovative motor technology for hybrid and electric' http://w3.siemens.com/topics/global/de/elektromobilitaet/PublishingImages/antriebe-pkw/pdf/sivetec-mrs-mri-siemens_en.pdf, Accessed November 2015.
- [29] 'Lenze Inverter Drives 8400 motec' <http://www.actechdrives.com/PDF/Lenze/Lenze-8400-Motec-Inverters.pdf>, Accessed November 2015.
- [30] 'Siemens Multiple Drive for Vertical Mills' <http://www.industry.siemens.com/drives/global/en/gear-units/application-specific-gear-units/vertical-mills/flender-multiple-drive/pages/default.aspx>, Accessed November 2015.
- [31] Wheeler P. W., Clare J. C., Apap M., et al., "An integrated 30kW matrix converter based induction motor drive", PESC '05. 2005. IEEE 36th Power Electronics Specialists Conference, IEEE. pp. 2390 – 2395
- [32] Wheeler P. W., Rodriguez J., Clare J. C., et al., "Matrix converters: a technology review", IEEE on Industrial Electronics, 2002. **49**, (2), pp. 276-288.
- [33] 'UQM and Kinetics present integrated motor and multi-speed transmission for commercial Evs' <https://chargedevs.com/newswire/uqm-and-kinetics-present-integrated-motor-and-multi-speed-transmission-for-commercial-evs/>, Accessed November 2015
- [34] 'Bonfiglioli 600D - Electric powertrains for lightweight vehicles' <http://www.bonfiglioli.co.uk/en-gb/mobile/products/electric-solutions/powertrains/product/600d-electric-powertrain/>, Accessed November 2015
- [35] 'E-Trac IMD integrated motor drive' http://www.southernpower.com/pdf/woods/electronic_products_guide.pdf, Accessed November 2015
- [36] Henze, M. "The Integral Motor – a new variable-speed motor"³⁰

drive”,

<https://library.e.abb.com/public/82be3ed09497afb3c1256ddd00346fb6/04-08m181.pdf>,

Accessed

November 2015

[37] Fraser, A. “IN-WHEEL ELECTRIC MOTORS - The packaging and integration challenges,” http://www.proteanelectric.com/wp-content/uploads/2013/07/In_Wheel_Electric_Motors_AFraser_ProteanV4.pdf Accessed Apr. 12, 2015.

[38] Perovic, D. “Making the impossible, possible – Overcoming the design challenges of in wheel motors,” EVS26 International Battery, Hybrid and Fuel Cell Electric Vehicle Symposium, 2012, **5**, pp 514-519.

[39] Mueller S. I., Nellis G. F., T. M. Jahns, “Model and design of an aircooled thermal management system for an integrated motor-controller”, in Proc. of 2005 CPES Power Electronics Seminar, pp. 145-152

[40] ‘Integrated IE4 motor-drive is 'up to 40% smaller' Yaskawa 4kW <http://en.ofweek.com/new-products/Integrated-IE4-motor-drive-is-up-to-40-smaller-23406> , accessed November 2015

[41] ‘Baldor SmartMotor’ <http://www.baldor.com/Shared/manuals/750-902.pdf> Accessed November 2015

[42] ‘Getting more from the motor’ <http://eandt.theiet.org/magazine/2015/02/efficient-motor-drives.cfm>, Accessed November 2015

[43] ‘Grundfoss E-pumps’ <https://us.grundfos.com/content/dam/GPU/Literature/LCSE-LFE/LCBSSL04-0614-Grundfos-E-Pump-Brochure.pdf>, Accessed November 2015

[44] ‘Rockwell Automation Kinitex 6000’ http://literature.rockwellautomation.com/idc/groups/literature/documents/td/gmc-td001_-en-p.pdf,

Accessed November 2015

[45] ‘Variable speed motor or geared motor’ http://www.leroy-somer.com/documentation_pdf/3415_en.pdf

Accessed November 2015

[46] ‘MOVIMOT® gearmotor with integrated frequency inverter’ <http://www.seweurodrive.com/produkt/movimot-gearmotor-with-integrated-frequency-inverter.htm>,

Accessed November 2015

[47] ‘Lenze smart motor M300’ http://www.lenze.com/fileadmin/lenze/documents/en/catalogue/CAT_MT_MS_13449851_en_GB.pdf,

Accessed November 2015

[48] Miller. T. J., “Electrical Energy Storage for Vehicles: Targets and Metrics” <http://www.arpa-e.energy.gov/sites/default/files/documents/files/Ford%20Presentation.pdf>, Accessed November 2015

[49] ‘Alpha step series’ <http://www.orientalmotor.com/products/stepper-motors/ASX-series-all-in-one-stepper-motor.html>, Accessed November 2015

[50] INMOCO http://www.inmoco.co.uk/pegasus_integrated_servo_system, Accessed November 2015

[51] ‘AXOR fastback’ <http://www.motioncontrolproducts.com/pdfs/axor-fast-back-brushless-motor-with-drive.pdf>, Accessed November 2015

[52] Johnson R. W., "A review of high temperature electronics packaging," Proceedings of the 1989 ' High Temperature Electronics Conference.

[53] Olesen K., Bredtmann R., Eisele R., ““ShowerPower” new cooling concept for automotive applications”, Automotive Power Electronics. 2006

- [54] Hearn J. A., "Future packaging technologies for hybrid electronics in automotive underhood environment," Proceedings of the 1989 High Temperature Electronics Conference, 1989.
- [55] Stolpa S., "Turbulent heat transfer". Department of Aerospace and Mechanical Engineering, University of Notre Dame, Notre Dame, USA, April 2004.
- [56] McClusky P., Grzybowski R. R., et al., "Packaging of electronics for high temperature applications," International Journal of Microcircuits and Electronic Packaging, 1997. **20**, (3)
- [57] Mantooth H. A., Mojarradi M. M., Johnson R. W., "Emerging capabilities in electronics technologies for extreme environments. Part I - High temperature electronics", IEEE Power Electronics Society Newsletter, issue 1, 2006.
- [58] Şenyıldız T., Eisele R. , Olesen K., "Thermal management concepts for power electronic modules" Danfoss Silicon Power GmbH, 2003.
- [59] Liang Z., Ning P., Wang F., "Advanced packaging of sic power module for automotive applications," Energy Conversion Congress and Exposition (ECCE), Sept. 2013 IEEE, pp.2884,2891, 15-19.
- [60] Liang Z, Li L., "HybridPACK2 - advanced cooling concept and package technology for hybrid electric vehicles," Vehicle Power and Propulsion Conference, Sept. 2008. VPPC '08. IEEE, pp.1, 5, 3-5
- [61] Haque S., Xing K.; Suchicital C., et al., "Thermal management of high-power electronics modules packaged with interconnected parallel plates," Semiconductor Thermal Measurement and Management Symposium, Mar 1998. SEMI-THERM Proceedings 1998, Fourteenth Annual IEEE, pp.111, 119, 10-12
- [62] Yong W., Guang Y., Yong-Kyu Y., et al., "Active cooling substrates for thermal management of microelectronics," Components and Packaging Technologies, IEEE Transactions on , **28**, (3), 2005. pp.477-483
- [63] Ozpineci B., Tolbert L. M., Islam S. K., et al., "Testing, characterization and modelling of SiC diodes for transportation applications", IEEE Power Electronics Specialists Conference 2002. IEEE. pp. 1673–1678
- [64] Ghandhi S. K., "Semiconductor power devices", Wiley, 1977 republished 1998.
- [65] Baliga B. J., "Physics of semiconductor power devices". JWS Publishing, 1996.
- [66] Shur M. S., Gaska R., Khan A., Simin G., "Wide band gap electronic devices", Fourth IEEE International Caracas Conference on Devices, Circuits and Systems 2002. IEEE pp. 51-58
- [67] O'Connor J., Smiltens J., "Silicon carbide, a high temperature semiconductor", New York: Symposium Publications Division, Pergamon Press, 1960.
- [68] Hudgins J. L., Simin G. S., Khan M. A., "A new assessment of the use of wide bandgap semiconductors and the potential for GaN", Power Electronics Specialists Conference, 2002.4, pp. 1747-1752
- [69] Hornberger J., Lostetter A. B., Olejniczak K. J., et al., "Silicon-carbide (SiC) semiconductor power electronics for extreme high-temperature environments", Aerospace Conference, 2004. Proceedings, **4**, IEEE. pp. 2538 – 2555
- [70] Trivedi M., Shenai K., "Performance evaluation of high-power wide band-gap semiconductor rectifiers", Journal of Applied Physics, 1999. **85**, (9), pp. 6889-6897
- [71] v. Muench M., Hoeck P., Pettenpaul E., IEEE Int. Electron Device Mtg. Tech. Dig. 337 1977.
- [72] Ebert W., Vescan A., Borst T. H., Kohn E., IEEE Intl. Electron Device Mtg. Tech. Dig. 419 1994.
- [73] Shin M. W., Trew R. J., Bilbro G. L., "High temperature DC and RF performance of p-type diamond MESFET: comparison with n-type GaAs MESFET", IEEE Electron Device Letters, **15**, pp. 1994. 292-294

- [74] Weitzel C. E., Palmour J. W., Carter C. H., et al., "Silicon carbide high power devices", IEEE Transactions, Electron Devices, 1996. **43**, (10), pp. 1732-1741
- [75] Ozpineci B., Chinthavali M. S., Tolbert L. M., "Enhancing power electronic devices with wide band gap semiconductors", International Journal of High Speed Electronics and Systems, 2006 APA. pp. 545556
- [76] Ozpineci B., Tolbert L. M., "Comparison of wide-band gap semiconductors for power electronics applications". United States. Department of Energy, 2003.
- [77] Shenai K., Scott R. S., Baliga B. J., "Optimum semiconductors for high power electronics", IEEE Trans Electron Devices, **36**, (1811), 1989.
- [78] Bhalla A., Chow T. P., "Examination of semiconductors for bipolar power devices", Inst Phys Conf Ser, **137**, (621), 1994.
- [79] Bhalla A., Chow T. P., "Bipolar power device performance: dependence on materials, lifetime and device ratings", in: Proceedings of the 6th International Symposium on Power Semiconductor Devices and ICs, 1994. pp. 287-292
- [80] Baliga B. J., "Power semiconductor device figure of merit for high frequency applications", IEEE Electron Device Letters, 1989. **10**, (10), pp. 455-457
- [81] Chow T. P., Tyagi R., "Wide bandgap compound semiconductors for superior high-voltage power devices", IEEE Trans Electron Devices, **41**, (8), 1994. pp. 1481-1483
- [82] Chow T.P., Khemka V., Fedison J., et al., "SiC and GaN bipolar power devices", Solid-State Electronics, 2000. **44**, (2), pp. 277-301
- [83] Mishra U., "Compound semiconductors; GaN and SiC, separating fact from fiction in both research and business" http://www.apec-conf.org/wp-content/uploads/2014/01/2_APEC2013Plenary_Compound_Semiconductors_GaN_SiC_Mishra_Transphorm.pdf Accessed 10 Apr, 2015
- [84] Trivedi M., Shenai K., "High temperature capability of devices on Si and wide bandgap materials", Industry Applications Conference, 1998. IEEE, **2**, pp. 959-962
- [85] Microsemi PPG, "Gallium nitride (GaN) versus silicon carbide (SiC) In the High Frequency (RF) and power switching applications" http://www.digikey.co.uk/Web%20Export/Supplier%20Content/Microsemi_278/PDF/Microsemi_Gallium_Nitride_VS_SiliconCarbide.pdf?redirected=1 Accessed 08 Apr, 2015.
- [86] Extance A., "SiC and GaN power devices jostle to grow their role", Yole Development, Issue 9, 2013 http://www.yole.fr/iso_upload/mag/powerdev_april2013_ir.pdf 09 Apr, 2015
- [87] Tolbert L. M., Ozpineci B., King T. J., Cambell J. B., et al., "Power electronics for distributed energy systems and transmission and distribution applications", 2005.
- [88] Pearton S. J., Zolper J. C., Shul R. J., et al., "GaN: processing, defects, and devices," Journal of Applied Physics, 1999. **86**, (1)
- [89] Dang G. T., Zhang A. P., et al., "High-voltage GaN schottky rectifiers," IEEE Transactions on Electron Devices, 2002. **47**, (4), pp. 692-696

- [90] Hudgins J. L., Simm G. S., Khan M. A., "A new assessment of the use of wide bandgap semiconductors and the potential of GaN," The 33d Annual IEEE Power Electronics Specialists Conference (PESC02), 2002. pp. 1747–1752
- [91] Trivedi M., Shenai K., "Performance evaluation of high-power wide bandgap semiconductor rectifiers" American Physics Institute Journal of Applied Physics, 1999. **85**, (9), pp. 6889–6897
- [92] Benția I., Ruba M., Szabó L., "Modular electrical machines – a survey" Proceedings of the International Scientific Conference MicroCAD, 2010.
- [93] van der Duijn Schouten, N.P.; Gordon, B.M.; McMahon, R.A.; Boger, M.S., "Integrated drives as single-phase motor replacement," Industry Applications Conference, 1999. Thirty-Fourth IAS Annual Meeting. Conference Record of the 1999 IEEE, **2**, pp.922, 928
- [94] März M.: Technology Choices for Automotive Applications. Int. Conf. on Automotive Power Electronics (APE), Paris, 2007
- [95] Klumpner C., Blaabjerg F., Thogersen P., "Evaluation of the converter topologies suited for integrated motor drives", 38th IAS Annual Meeting Conference Record of the Industry Applications Conference, 2003, **2**, IEEE. pp. 890 – 897
- [96] Simon O., Mahlein J., Muenzer M. N., Bruckmarm M., "Modern solutions for industrial matrix-converter applications", IEEE Transactions on Industrial Electronics, 2002, **49**, (2), IEEE. pp. 401 – 406
- [97] Pan M. J., Randall C. A., "A brief introduction to ceramic capacitors," Electrical Insulation Magazine, 2010. **26**, (3), pp. 44-50
- [98] Randall M., Skamser D., Kinard T., "Thin film MLCC", in CARTS 2007 Symposium Proceedings, Albuquerque, 2007. NM, pp. 1–12,
- [99] Takamizawa H., Utsumi K., Yonezawa M., et al., "Large capacitance multilayer ceramic capacitor", IEEE Transactions on Components, Hybrids, and Manufacturing Technology, 1981. **4**, (4), pp. 345-349
- [100] Yano Research Institute, "Capacitor market in japan: key research findings 2009," Yano Research Institute, Tokyo, Japan, Nov. 2009.
- [101] Phillips R., Bultitude J., Gurav A, et al., "High temperature ceramic capacitors for deep well applications", CARTS International Proceedings, 2013.
- [102] Kim W., Shin S. H., Ryu D. S., "Reliability evaluation and failure analysis for high voltage ceramic capacitor", Advances in Electronic Materials and Packaging, 2001. pp. 286-195
- [103] Al Ahmar J., Wiese S., "Fracture mechanics analysis of cracks in multilayer ceramic capacitors", Electronics System-Integration Technology Conference (ESTC), 2014. pp. 1-15
- [104] Teverovsky A., "Insulation resistance and leakage currents in low-voltage ceramic capacitors with cracks", IEEE Transactions on Components, Packaging and Manufacturing Technology, 2014. **4**, (7), pp. 1169-1176
- [105] B. Kirisken, H. F. Ugurdag, "Cost-Benefit Approach to Degradation of Electrolytic Capacitors", Reliability and Maintainability Symposium, pp. 1-6, 2014.
- [106] Deshpande R. P., "Capacitors: technology and trends" Tata McGraw-Hill Education, 2012.
- [107] Bramoulle M., "Electrolytic or film capacitors", Industry Applications Conference, Thirty-Third IAS Annual Meeting, 1998. **2**, pp. 1138-1142

- [108] Parler Jr. S. G., "Deriving life multipliers for electrolytic capacitors," IEEE Power Electronics Society Newsletter, 2004. **16**, pp. 11-12
- [109] Maddula S.K., Balda J.C., "Lifetime of electrolytic capacitors in regenerative induction motor drives," in Power Electronics Specialists Conference, 2005. pp. 153- 159
- [110] Spanik P., Frivaldsky M., Kanovsky A., "Life time of the electrolytic capacitors in power applications", ELEKTRO, 2014. 233-238
- [111] Sarjeant W. J., Zirnheld J., MacDougall F. W., "Capacitors", IEEE Transactions on Plasma Science, 1998. **26**, (5), 1368-1392
- [112] Yaohong C., Fuchang L., Hua L., "Study on self-healing and lifetime characteristics of metallized film capacitor under high electric field", 2011. Pulsed Power Conference (PPC), pp. 711-716
- [113] "The new high temperature dielectric film for power capacitors" Accessed November 2015 http://www.birkelbachfilm.de/pdf/datenblaetter/DTF_Teonex_HV_0912.pdf
- [114] Caliarì L., Bettacchi P., Boni E., et al., "KEMET film capacitors for high temperature, high voltage and high current", CARTS International Proceedings – ECA, 2013.
- [115] Klumpner C., Blaabjerg F., Thogersen P., "Converter topologies with low passive components usage for the next generation of integrated motor drives", Power Electronics Specialist Conference, PESC '03. 2003 IEEE 34th Annual, **2**, IEEE. pp. 568 – 573
- [116] Lewandowski A., Jakobczyk P., Galinski M., et al., "Self-discharge of electrochemical double layer capacitors", Physical Chemistry Chemical Physics, 2013. **22**, (15), pp. 8692-8699
- [117] Becker H. I., U.S. pat., 2800.616 to General Electric Co., 1957.
- [118] Wang G., Zhang L., Zhang J., "A review of electrode materials for electrochemical supercapacitors", Chemical Society Reviews, 2012. **2**, (41), pp. 797-828,
- [119] Burke A., "Power sources", 2000, 91, 37. 2000.
- [120] Chen H., Cong T. N., Yang W., Tan C., et al., Prog. Nat. Sci., 19, 291, 2009.
- [121] Lambert S.M., Pickert V., Holden J., et al., "Comparison of supercapacitor and lithium-ion capacitor technologies for power electronics applications," 5th IET International Conference on Power Electronics, Machines and Drives (PEMD 2010), April 2010. pp.1,5, 19-21
- [122] Neudeck P.G., Matus L.G., "An overview of silicon carbide device technology," Ninth Symposium on Space Nuclear Power Systems, 1992. pp. 12–16
- [123] Casady J. B., Dillard W. C., Johnson R. W., et al., "A hybrid 6H-SiC temperature sensor operational from 25 C to 500 C," IEEE Transactions on Components, Packaging and Manufacturing Technology, 1996. **19**, (3), pp. 416–422
- [124] Khazaka R., Mendizabal I., Henry D., et al., "Survey of high-temperature reliability of power electronics packaging components," , IEEE Transactions on Power Electronics, 2015. **30**, (5), pp.2456-2464
- [125] Funaki T., Balda J.C., Junghans J., et al., "Power conversion with SiC devices at extremely high ambient temperatures," IEEE Transactions on Power Electronics, July 2007. **22**, (4), pp.1321, 1329
- [126] Bai J. G., Yin J., Zhang Z., et al., "High temperature operation of SiC power devices by low-temperature sintered silver die-attachment," IEEE Trans. Adv. Package., 2007. **30**, (3), pp. 506–510

- [127] Lei T. G., Calata J. N., Luo S., et al., "Low temperature sintering of nanoscale silver paste for attaching large-area ($>100 \text{ mm}^2$) chips," *IEEE Trans. Comp. Package. Technol.*, 2010. **33**, (1), pp. 98–104
- [128] Savrun E., "Packaging considerations for very high temperature microsystems," in *Proc. 1st IEEE Sens.*, 2002. **2**, pp. 1139–1143
- [129] Das M. K., Sumakeris J. J., Hull B. A., et al., "Drift-free, 50 A, 10 kV 4H-SiC pin diodes with improved device yields", *Materials Science Forum*, 2005. **483-485**, pp. 965-968
- [130] ROHM full SiC power Module Data sheet Available
http://rohms.rohm.com/en/products/databook/datasheet/discrete/sic/power_module/bsml80d12p2c101.pdf
 Accessed 08 Apr, 2015.
- [131] Mitsubishi SiC Power modules.
http://www.mitsubishielectric.com/semiconductors/catalog/pdf/SiCPowerModules_E_201409.pdf
 Accessed Apr 08, 2015.
- [132] Schupbach R. M., McPherson B., McNutt T., et al., "High temperature (250 °C) SiC power module for military hybrid electrical vehicle applications," in *NDIA Ground Veh. Syst. Eng. Technol. Symp.*, Aug. 2011, pp. 1–7.
- [133] Horio M., Iizuka Y., Ikeda Y., "Packaging technologies for SiC power modules", *Fuji Electric Review*, 2012. **58**, (2), pp. 75-78
- [134] Chen Z., Yao Y., Boroyevich D., et al., "A 1200 V, 60 A SiC MOSFET multi-chip phase-leg module for high-temperature, high-frequency applications," *Applied Power Electronics Conference and Exposition (APEC)*, 2013 Twenty-Eighth Annual IEEE, pp.608-615
- [135] Ning P., Lai R., Huff D., Wang F., et al., "SiC wirebond multichip phase-leg module packaging design and testing for harsh environment," *IEEE Trans. Power Electron.*, 2010. **25**, (1), pp. 16–23
- [136] Katsis D., Zheng Y., "Development of an extreme temperature range silicon carbide power module for aerospace applications," in *Proc. 39th IEEE Power Electron. Spec. Conf.*, 2008. pp. 290–294
- [137] Yao Y., Chen Z., Lu G.-Q., "Characterization of encapsulants for high-voltage high-temperature power electronic packaging," *IEEE Trans. Components, Packaging and Manufacturing Technology*, 2012. **2**, (4), pp. 539–547
- [138] Yiyang Y., Guo-Quan L., Boroyevich D., et al., "Survey of high-temperature polymeric encapsulants for power electronics packaging," *IEEE Transactions on Components, Packaging and Manufacturing Technology*, 2015, **5**, (2), pp.168-181
- [139] Kodani K., Tsukinari T., Matsumoto T., "New power module concept by forced-air cooling system for power converter," *Power Electronics Conference (IPEC)*, June 2010. International, pp.542, 545, 21-24
- [140] Johnson R. W., Palmer M., Wang C., et al., "Packaging materials and approaches for high temperature SiC power devices", *Advancing Microelectronics*, 2004. **31**, (1), pp. 8-11
- [141] Mustain H. A., Lostetter A. B., Brown W. D., "Evaluation of gold and aluminium wire bond performance for high temperature (500 °C) silicon carbide (SiC) power modules", *Electronic Components and Technology ECTC 2005*, **2**, pp. 1623-1628
- [142] Salmon J. S., Johnson R. W., Palmer M., "Thick film hybrid packaging techniques for 500°C operation," in *Proc. 4th Int. High Temp. Electron. Conf. (HITEC)*, 1998. pp. 103–108

- [143] Jian Y., Zhenxian L., van Wyk J. D., "High temperature embedded SiC chip module (ECM) for power electronics applications," *IEEE Transactions on Power Electronics*, 2007. **22**, (2), pp.392-398
- [144] Bower G., Rogan C. P. E., Kozlowski J., et al., "SiC power electronics packaging prognostics", aerospace conference, 2008. pp. 1-12
- [145] Zhenxian L., "Packaging technologies to exploit the attributes of WBG power electronics," *IEEE Workshop on Wide Bandgap Power Devices and Applications (WiPDA)*, 2014, pp. 1-73
- [146] Pooch M. H., Dittmer K. J., Gabisch D., "Investigations on the damage mechanism of aluminium wire bonds used for high power applications," in *Proc. Eur. Conf. Electr. Packaging Technol.*, 1996. pp. 128–131
- [147] Chen L., Neudeck P. G., "Thick and thin film materials based chip level packaging for high temperature SiC sensors and devices," *Tech. Rep.*, AYT/NASA Glenn Research Center, 2001.
- [148] Cressler, J. D., Mantooth H. A., "Extreme Environment Electronics" (CRC Press, Florida, 2012)
- [149] Cheng, C.H.; Hsiao, H.L.; Chu, S.I.; Shieh, Y.Y.; Sun, C.Y.; Peng, C., "Low cost silver alloy wire bonding with excellent reliability performance," in *Electronic Components and Technology Conference (ECTC)*, 2013 IEEE 63rd, vol., no., pp.1569-1573, 28-31 May 2013.
- [150] Lu, C., "Review on silver wire bonding," in *Microsystems, Packaging, Assembly and Circuits Technology Conference (IMPACT)*, 2013 8th International, vol., no., pp.226-229, 22-25 Oct. 2013
- [151] Xiao, Y.; Natarajan, R.; Chow, T.P.; Rymaszewski, E.J.; Gutmann, R.J., "Flip-chip flex-circuit packaging for 42 V/16 A integrated power electronics module applications," in *Applied Power Electronics Conference and Exposition*, 2002. APEC 2002. Seventeenth Annual IEEE, vol.1, no., pp.21-26 vol.1, 2002
- [152] Bai, John G.; Guo-Quan Lu; Liu, Xingsheng, "Flip-chip on flex integrated power electronics modules for high-density power integration," in *Advanced Packaging*, *IEEE Transactions on*, vol.26, no.1, pp.54-59, Feb. 2003.
- [153] Muralidharan G., Tieggs T. N., "Composite die-attach materials for high-temperature packaging applications", *High Temperature Electronics Conference HITEC*, 2006.
- [154] Jacob P., Held M., Sacco P., et al., "Reliability testing and analysis of IGBT power semiconductor modules," *The IEEE Colloquium IGBT Propulsion Drives*, 1995. pp. 4/1–4/5
- [155] Knoerr M., Kraft S., Schletz A., "Reliability assessment of sintered nano-silver die attachment for power semiconductors," in *Proc. 12th Electron. Package. Technol. Conf.*, 2010. pp. 56–61
- [156] Buttay C., Masson A., Li J., et al., "Die attach of power devices using silver sintering bonding process optimization and characterization," *The IMAPS High Temperature Electron. Netw.*, 2011.
- [157] Manikam V. R., Cheong K. Y., "Die attach materials for high temperature applications: a review," *IEEE Trans. Compon., Package. Manuf. Technol.*, 2011. **1**, (4), pp. 457–478
- [158] Hopkins D. C., Kellerman D. W., Wunderlich R. A., et al., "High-temperature, high-density packaging of a 60kW converter for >200°C embedded operation", *Applied Power Electronics Conference and Exposition*, 2006.
- [159] Humpston G., Jacobson D. M., "Principles of Soldering", *ASM International*, 2004.
- [160] Welch III W. C., Chae J., Najafi K., "Transfer of metal MEMS packages using a wafer-level solder transfer technique", *IEEE Transactions on Advanced Packaging*, 2005. **28**, (4), pp 643–649

- [161] Bai J. G., Zhang Z. Z., Calata J. N., et al., "Low-temperature sintering of nanoscale silver paste: a lead-free die-attach solution for high-performance and high-temperature electronic packaging", High Temperature Electronics Conference, 2012.
- [162] Pan Wei Chih; Mesa, B.J.A.; Xie Hong; Goh Min Hao, "Application and high temperature storage test on Zn-Al-Ge high temperature solder for die attach," in Electronics Packaging Technology Conference (EPTC), 2014 IEEE 16th , vol., no., pp.463-468, 3-5 Dec. 2014
- [163] McCluskey F. P., Wang Z., Dash M., Huff D., "Reliability of high temperature solder alternatives", High Temperature Electronics Conference HITEC, 2006.
- [164] Lu G-Q., Calata J. N., Zhang Z., Bai J. G., "A lead-free, low-temperature sintering die-attach technique for high-performance and high temperature packaging", IEEE CPMT Conference on High Density Microsystem Design and Packaging and Component Failure Analysis HDP 2004, pp. 42–46
- [165] Wu M., Lu G-Q, Yin J., et al., "Thermal modelling and electrical analysis of the nano-silver paste die-attached power device package at high temperature", CPES Conference and Site Visit, 2006.
- [166] Joo S., Baldwin D. F., "Rapid prototyping of micro-systems packaging using a data-driven chip-first process and nano-particles metal colloids", Advancing Microelectronics, 2006. pp. 11-14
- [167] Parylene Properties. Available: http://scscoatings.com/what_is_parylene/parylene_properties.aspx. Accessed Apr. 8, 2015.
- [168] Miyoshi, Hiromasa; Endoh, Keiichi; Kurita, Satoru, "Application of Silver Nano Particle to Pressureless Bonding onto a Copper Surface - Consideration of Substitute Material for Lead Solder," in Integrated Power Systems (CIPS), 2014 8th International Conference on , vol., no., pp.1-5, 25-27 Feb. 2014
- [169] Cao X., Wang T., Ngo K. D. T., et al., "Parametric study of joint height for a medium-voltage planar package," IEEE Trans. Comp. Package. Technol., Sep. 2010. **33**, (3), pp. 553–562
- [170] Cao X., Wang T., Ngo K. D. T., et al., "Height optimization for a medium-voltage planar package," in Proc. 24th Annual. IEEE Appl. Power Electron. Conf. Expos., Washington D.C., Feb. 2009, pp. 479–484.
- [171] Zhang Z., Bai J. G., Lu G-Q, et al. "Low-temperature Sintering Nanoscale Silver Paste as an High-Temperature package Solution", CPES Conference and Site Visit, 2005.
- [172] Cyclotene* 3000 Series—Processing Procedures for CYCLOTENE 3000 Series Dry Etch Resins. Available: http://msdssearch.dow.com/PublishedLiteratureDOWCOM/dh_08b4/0901b803808b4ed7.pdf?filepath=/888-00006.pdf&fromPage=GetDoc , Accessed Apr. 8, 2015.
- [173] Cyclotene* 4000 Series—Processing Procedures for CYCLOTENE 4000 Series Resins-DS3000 Immersion Develop Process. Available: http://msdssearch.dow.com/PublishedLiteratureDOWCOM/dh_08b4/0901b803808b4eda.pdf?filepath=/888-00008.pdf&fromPage=GetDoc. Accessed Apr. 9, 2015.
- [174] P84 Polyimide Solution—Technical Information. Available: <http://hppolymer.com/pdfs/P84-%20Polyimide%20Solution1.pdf>. Accessed Apr. 9, 2015.
- [175] Davis J. H., Rees D. W., Riley I. H., "Silicone encapsulating and potting materials," Proc. IEE-B, Electron. Commun. Eng., 1962. **109**, (21), pp. 266–270

- [176] Wong C. P., Segelken J. M., Balde J. W., "Understanding the use of silicone gels for non-hermetic plastic packaging," IEEE Trans. Compon., Hybrids, Manuf. Technol., Dec. 1989. **12**, (4), pp. 421–425
- [177] Durapot Epoxies—High Performance Casting, Embedding and Encapsulating Compounds. Available: <http://www.cotronics.com/vo/cotr/pdf/860.pdf>, accessed Apr. 8, 2015.
- [178] CF-4721—Technical Data Sheet. Available: <http://nusil.com/products/ProductProfiles/CF-4721/CF-4721P.pdf>, accessed Apr. 9, 2015.
- [179] Technical Data Sheet—QSIL 550 2-Part Addition Cure Encapsulant. Available: <http://www.acc-silicones.com/content/products/qsil573.ashx>, Accessed Apr. 8, 2015.
- [180] EPM-2422—Technical Data Sheet. Available: <http://www.silicone-polymers.com/pdfMaster/EPM-2422P.pdf>, accessed Apr. 9, 2015.
- [181] R-2188—Technical Data Sheet. Available: <http://nusil.com/products/ProductProfiles/R-2188/R-2188P.pdf>, accessed Apr. 8, 2015.
- [182] Scofield J. D., Merrett J. N., Richmond J., et al., "Performance and reliability characteristics of 1200 V, 100 A, 200°C half-bridge SiC MOSFET-JBS diode power modules," in Proc. Int. Conf. High Temperature Electron. (HiTEC), Albuquerque, NM, USA, May 2010.
- [183] Niwa, K.; Nakamura, J.; Murakawa, K.; Nakamura, M., "New alumina substrate for hybrid integrated circuits," IEEE Transactions on Parts, Hybrids, and Packaging, Dec 1974. **10**, (4), pp.262, 266
- [184] Ji H., Cheng X., Chen H., et al. "Direct bonding of alumina substrate with copper heat sink in air assisted by ultrasonic vibrations for high power LEDs devices," 14th International Conference on Electronic Packaging Technology (ICEPT), Aug. 2013, pp.1158,1161, 11-14
- [185] Chen L. Y., "Temperature dependent dielectric properties of polycrystalline AlN substrates with yttrium oxide additives", High Temperature Electronics Conference HITEC 2006, May 2006.
- [186] Savrun E., Wu D., "High-temperature dielectric properties of aluminum nitride", High Temperature Electronics Conference HITEC 2006, May 2006.
- [187] Mounce S., McPherson B., Schupbach R., et al., "Ultra-lightweight, high efficiency sic based power electronic converters for extreme environments," Aerospace Conference, 2006 IEEE, pp.19
- [188] Beica, R., "Flip chip market and technology trends," Microelectronics Packaging Conference (EMPC), 2013 European, pp.1,4, 9-12 Sept. 2013. Chou, B.; Beilin, S.; Jiang, H.; Kudzuma, D.; Lee, M.; McCormack, M.; Massingill, T.; Peters, M.; Roman, J.; Takahashi, Y.; Wang, V., "Multilayer high density flex technology," Electronic Components and Technology Conference, 1999. 1999 Proceedings. 49th, vol., no., pp.1181, 1189, 1999.
- [189] Chou, B.; Beilin, S.; Jiang, H.; et al., "Multilayer high density flex technology," Electronic Components and Technology Conference, 1999. Proceedings. 49th, pp.1181, 1189
- [190] Woo, D.R.M., Hwang H. Y., Li J.A.J. et al., "High power SiC inverter module packaging solutions for junction temperature over 220°C," Electronics Packaging Technology Conference (EPTC), Dec. 2014. IEEE 16th , pp.31,35, 3-5
- [191] Pascariu, G.; Cronin, P.; Crowley, D., "Next generation electronics packaging utilizing flip chip technology," Electronics Manufacturing Technology Symposium, July 2003. IEMT 2003. IEEE/CPMT/SEMI 28th International, pp.423, 426, 16-18

- [192] X. Liu, S. Xu, G.-Q. Lu, and D. A. Dillard, "Effect of substrate flexibility on solder joint reliability," *Microelectron. Rel.*, vol. 42, pp. 1883–1891, 2002
- [193] Bivragh, M.; Kelley, M.; Van Sinte Jans, J.-B.; Indrajit, P.; Slattery, O.; Barton, John; O'Mathuna, S.C.; O'Flynn, B.; Malshe, A.P., "Thermo-mechanical modelling and thermal performance characterisation of a 3D folded flex module," in *Electronic Components and Technology Conference*, 2006. Proceedings. 56th , vol., no., pp.6 pp.-, May 30 2006-June 2 2006
- [194] Stockmeier, T., Beckedahl, P., Gobl, C., Malzer, T., "SKiN: Double side sintering technology for new packages", ISPSD 2011.
- [195] Savrun E., "Packaging considerations for very high temperature Microsystems," *Proc. IEEE*, 2002. **2**, (6), pp. 1139–1143
- [196] Sugawara Y., Takayama D., Asano K., "3 kV 600 a 4H-SiC high temperature diode module," in *Proc. Power Semicond. Devices ICs*, 2002. pp. 245–248
- [197] Nawa K., "Reliability study for CTE mismatching in build-up structure," *Electronic Components and Technology Conference*, 2001. Proceedings, 51st, pp.1154, 1158
- [198] Chandran B., Schmidt W.F., Gordon M.H., "A novel bonding technique to bond CTE mismatched devices," *Electronic Components and Technology Conference*, May 1996. Proceedings, 46th , pp.1151,1158, 28-31
- [199] Gerber M., Marz M., "System integration in automotive power systems," *European Conference on Power Electronics and Applications*, Sept. 2005, pp.10 -14
- [200] Jain, P.K., "Power electronics for low voltage semiconductor technology: challenges and some possible solutions," *Power Electronics and Motion Control Conference*, Aug. 2004. IPEMC 2004. The 4th International, **1**, pp.20, 28 14-16
- [201] Kolar J., Drogenik U., Biela J., et al., "PWM converter power density barriers," *Power Conversion Conference - Nagoya*, April 2007. PCC '07, pp. 2-5
- [202] van der Duijn Schouten, N.P.; Gordon, B.M., et al., "Integrated drives using high voltage power ICs," *Power Electronics and Variable Speed Drives*, 2000. Eighth International Conference on (IEE Conf. Publ. No. 475), pp.554, 559